

ZBK10-12BST Non-isolated DC-DC Converters
3.3V~14V Input 0.59V~5.1V/10A Output

Contents

Features..... 1
 Ordering Information..... 1
 Outline 2
 Specification 2
 Characteristic Curves (Vo=0.59V) 4
 Characteristic Curves (Vo=0.9V) 5
 Characteristic Curves (Vo=1.8V) 6
 Characteristic Curves (Vo=2.5V) 7
 Characteristic Curves (Vo=5.0V) 8
 Design Considerations 9
 Basic Connection 9
 Notes: The basic connection indicates the basic requirements that the power module can provide rated output voltage and rated power only. Please refer the instruction followed for further information..... 9
 Recommended Layout 9
 Input Voltage Range..... 9
 Remote Control..... 10
 External Capacitance 10
 Output Voltage Adjust..... 10
 Thermal Consideration 10
 ESD Control..... 11
 Quality Statement 11
 Contact Information..... 11



POL ZBK10 Series

Features

- ◆ Compact Size: 16.6mm × 10.5mm × 8.0mm
- ◆ Remote enable control (high level or float on)
- ◆ Wide input range: 3.3~14V
- ◆ Output adjustment (trim): 0.59V~5.1V
- ◆ Output Over Current Protection; Output Short-circuit Protection
- ◆ High efficiency: 93.5% (12V input, 5V output)
- ◆ Ambient temperature: -40°C ~ +85°C
- ◆ Output Current 10A
- ◆ Applications: Telecommunications, Electronic Data Processing, Distributed Power Architecture and Industry control.

Ordering Information

See Contents for individual product ordering numbers.

Suffix	Description	Ordering No.
_	Basic Part - Positive logic product	ZBK10-12BST
V	A fixed output voltage, such as: ZBK10-12BS 1V2.	ZBK10-12BST *V*
N	Negative logic product	ZBK10-12BSTN

ZBK10-12BST Non-isolated DC-DC Converters
3.3V~14V Input 0.59V~5.1V/10A Output

Outline

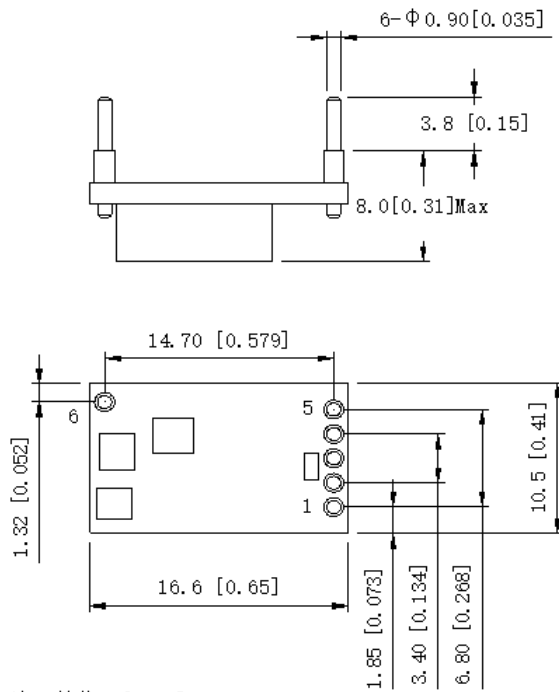

注：单位mm[inch]
 X.X±0.5[±0.02]; X.XXX±0.1[±0.010]

Pin	Symbol	Function
1	CNT	Remote Control, turn on/off the converter. Output voltage on when CNT floating or high level applied.
2	V _{in}	Positive Input
3	GND	Power ground
4	V _o	Positive Output
5	Trim	Output Voltage Trim, voltage be trimmed up or down by applying external resistor connected to +S or -S output
6	+S	Positive voltage sense

Material: FR4 PCB, Tinning pins

All dimensions in mm(inches)

Tolerances:X.X±0.5 (X.XX±0.02)

X.XX±0.25 (X.XXX±0.010)

Specification

Unless otherwise specified, all values are given at: 25°C, one standard atmosphere pressure, pure resistive load and basic connection; Input filter:22μF ceramic capacitance; output 10μF tantalum capacitance and 1μF ceramic capacitance.

Input	Symbol	Min	Typ	Max	Unit	Conditions	
Input Voltage	V _{in}	3.3	12.0	14.0	V	V _o ≤2.5V	
		4.3	12.0	14.0	V	V _o =3.3V	
		6.5	12.0	14.0	V	V _o =5.0V	
Positive Logic Control	On	-	0.8	-	14	V	Refer to GND ; Turn on when CNT floating.
	Current	-	-	-	1	mA	CNT source current when turn on
	Off	-	0	-	0.3	V	Refer to GND
	Current	-	-	-	1	mA	CNT sink current when turn on
Under Voltage Threshold	On	-	1.8	-	2.9	V	-
	Off	-	1.6	-	2.8	V	-

ZBK10-12BST Non-isolated DC-DC Converters
3.3V~14V Input 0.59V~5.1V/10A Output

Output	Symbol	Min	Typ	Max	Unit	Conditions	
Output Voltage	V_O	0.59	—	5.10	V	By input voltage	
Output Current	$I_{O,nom}$	0	—	10	A	-	
Line Regulation	SV	-	-	±5	mV	$V_o \leq 1.0V$	
		-	±0.2	±0.5	%VO	$V_o > 1.0V$	
Load Regulation	SI	-	-	±10	mV	$V_{in}=12V, V_o \leq 1.0V$	
		-	±0.5	±1	%VO	$V_{in}=12V, V_o > 1.0V$	
Output Over Current Protection Range	$I_{O,lim}$	12	-	-	A	$V_{in}=12V, V_o \geq 1.8V$	
Peak to Peak Ripple and Noise	ΔV_{pp}	-	30	100	mV	10 μ F tantalum capacitance and 1 μ F ceramic capacitance at output pins, 20 MHz, 40mm twisted pair	
Output Short-circuit Protection	Hiccup mode, automatic recovery, $V_o \geq 1.8V$,					—	
Rise Time	T_{rise}	—	5	—	ms	$I_{O,nom}$, Resistance load	
Output delay time	T_{delay}	—	10	—	ms	$I_{O,nom}$, Resistance load	
Capacitive Load	C_O	0	—	8400	μ F	$V_o=0.59V; V_o=0.9V$	
		0	—	2200	μ F	$V_o=1.8V; V_o=2.5V$	
		0	—	1100	μ F	$V_o=5.0V$	
Load Transient	Recovery Time	t_{tr}	—	25	50	μ s	$V_o:0.59 \sim 5.0V$
	Voltage deviation	ΔV_{tr}	—	±70	±150	mV	$V_o=0.59V$
			—	±50	±150	mV	$V_o=0.9V$
			—	±55	±150	mV	$V_o=1.8V$
			—	±60	±150	mV	$V_o=2.5V$
			—	±100	±150	mV	$V_o=5.0V$

General	Symbol	Min	Typ	Max	Unit	Conditions
Efficiency	η	—	95	—	%	$V_{in}=12V, 10A, V_o=5.0V$
		—	92	—	%	$V_{in}=12V, 10A, V_o=2.5V$
		—	84	—	%	$V_{in}=12V, 10A, V_o=1.8V$
		—	81	—	%	$V_{in}=12V, 10A, V_o=0.9V$
		—	73	—	%	$V_{in}=12V, 10A$
frequency	f_s	—	600	—	kHz	—

ZBK10-12BST Non-isolated DC-DC Converters
3.3V~14V Input 0.59V~5.1V/10A Output

Operating Ambient Temperature	—	-40	-	85	°C	—
MTBF	—	5×10^6	—	—	h	BELLCORE TR-332
Storage Temperature	—	-55	-	125	°C	—
Relative Humidity	—	10	-	90	%	40°C±2°C, No condensing
Temperature Coefficient	ST	—	—	±0.02	%/°C	-
Hand Soldering	Maximum soldering Temperature < 425°C, and duration < 5s					
Wave Soldering	Maximum soldering Temperature < 255°C, and duration < 10s					
Weight	—	—	4	—	g	—

Characteristic Curves (Vo=0.59V)

Load Transient Response

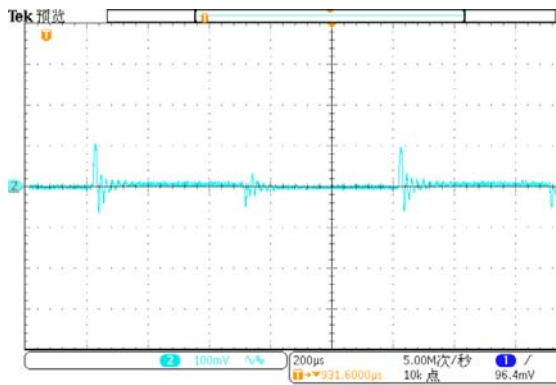

50%~100%~50% load, 0.1A/µs
 Vin=12Vdc

Output Ripple and noise

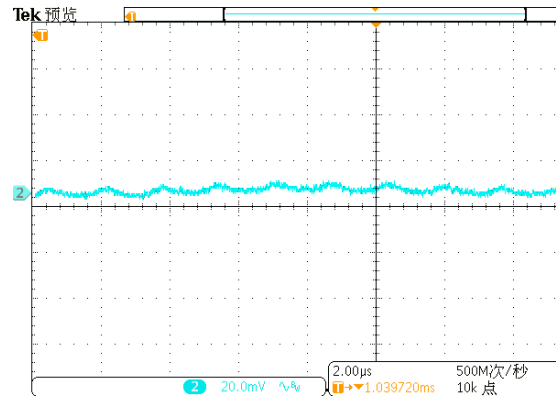

Vin=12Vdc

Output delay time

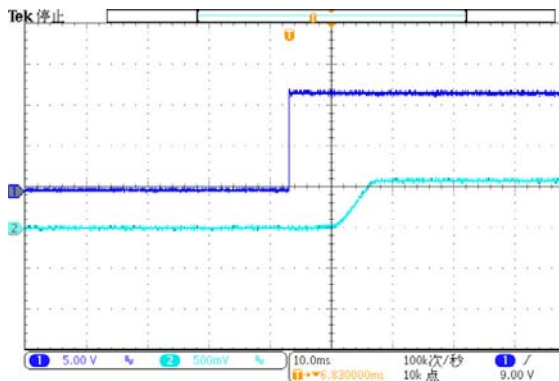

ZBK10-12BST Non-isolated DC-DC Converters
3.3V~14V Input 0.59V~5.1V/10A Output

Efficiency vs Io & Vin

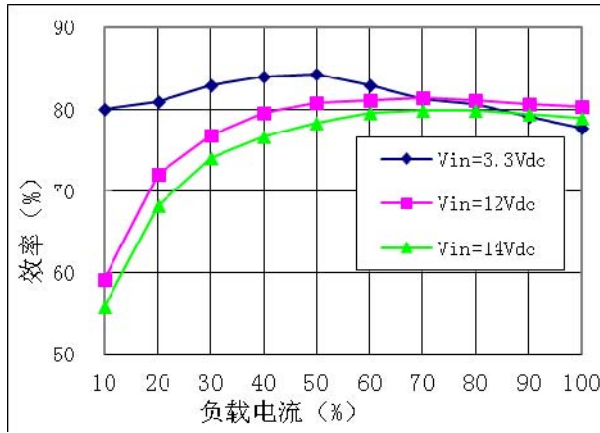

Derating (Vin=12Vdc)

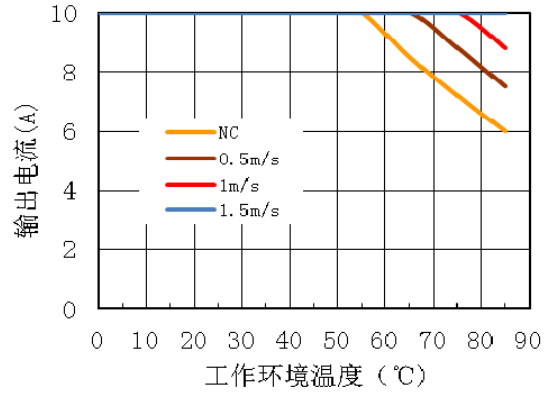

Characteristic Curves (Vo=0.9V)

Load Transient Response

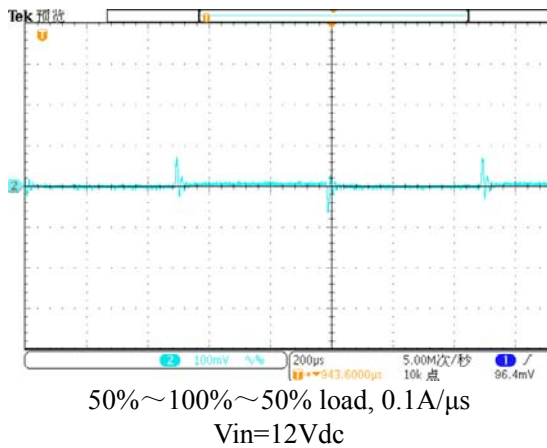

Output Ripple and noise

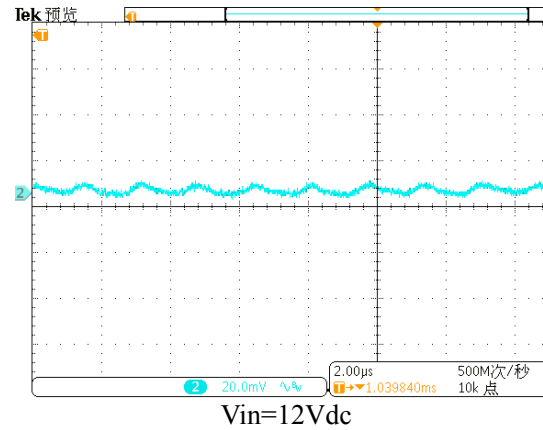

Output delay time

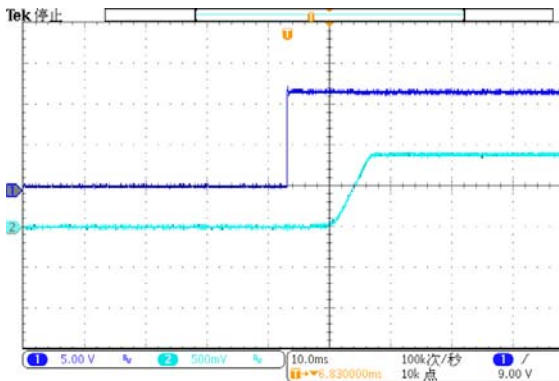

ZBK10-12BST Non-isolated DC-DC Converters
3.3V~14V Input 0.59V~5.1V/10A Output

Efficiency vs Io & Vin

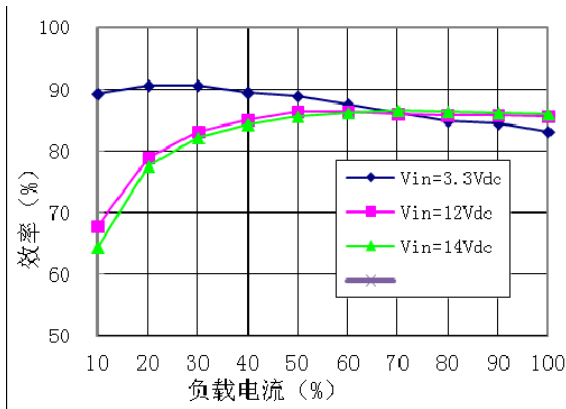

Derating (Vin=12Vdc)

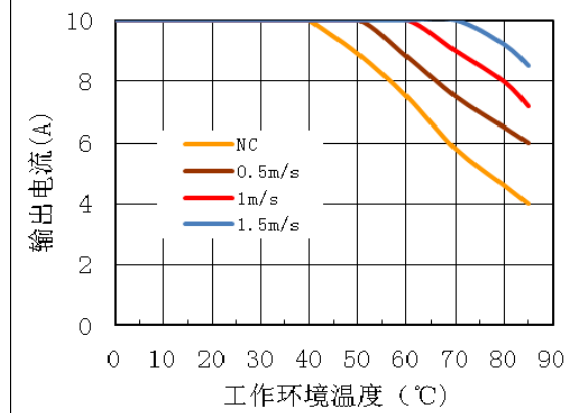

Characteristic Curves (Vo=1.8V)

Load Transient Response

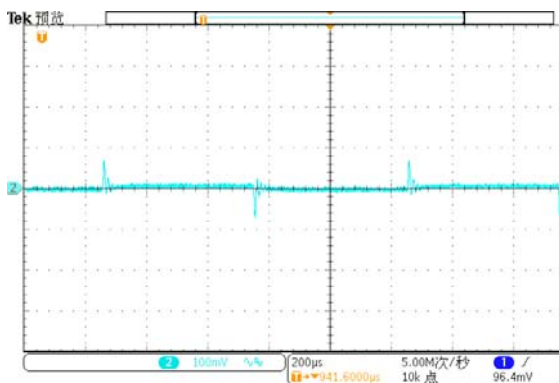

50%~100%~50% load, 0.1A/µs
 Vin=12Vdc

Output Ripple and noise

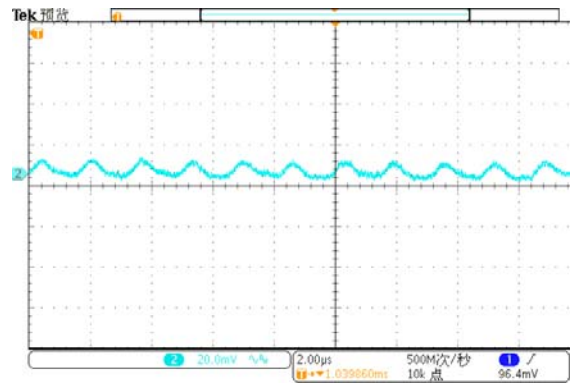

Vin=12Vdc

Output delay time

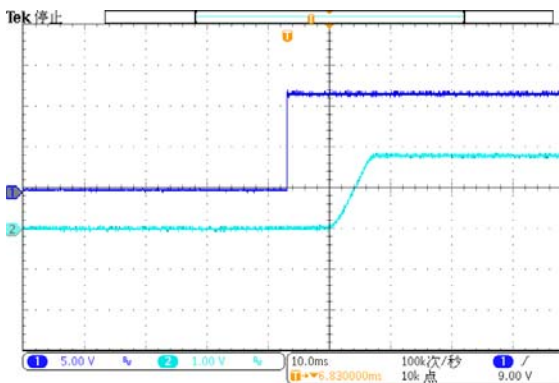

ZBK10-12BST Non-isolated DC-DC Converters
3.3V~14V Input 0.59V~5.1V/10A Output

Efficiency vs Io & Vin

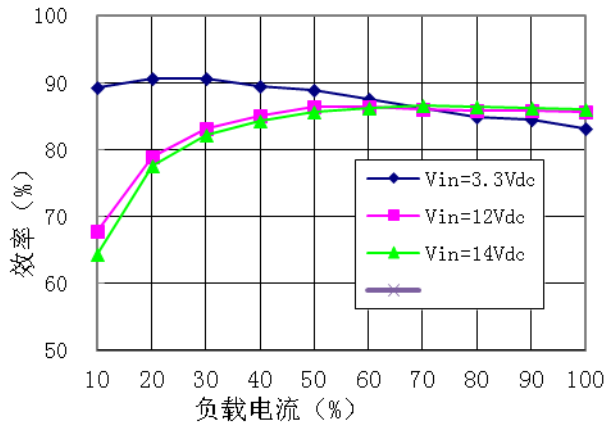

Derating (Vin=12Vdc)

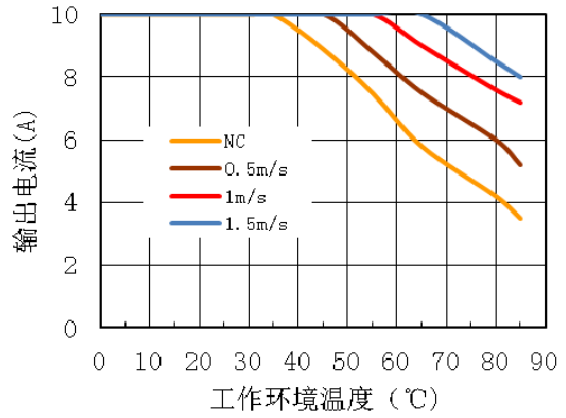

Characteristic Curves (Vo=2.5V)

Load Transient Response

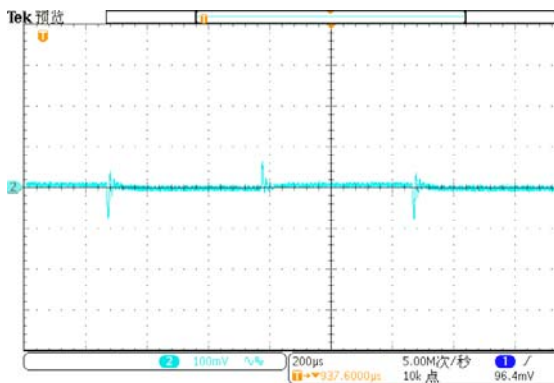

50%~100%~50% load, 0.1A/μs
 Vin=12Vdc

Output Ripple and noise

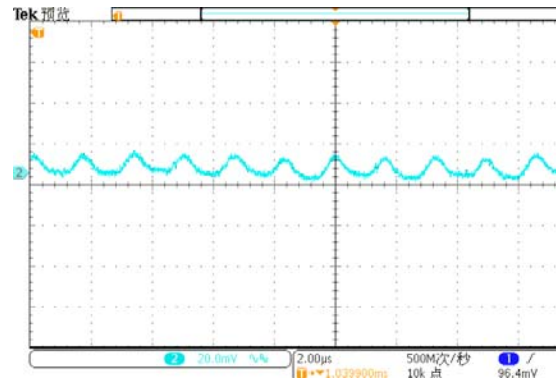

Vin=12Vdc

Output delay time

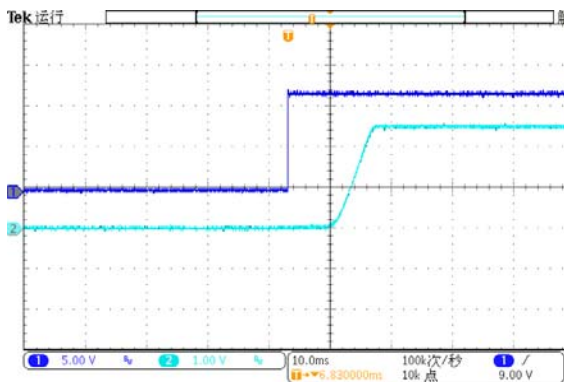

ZBK10-12BST Non-isolated DC-DC Converters
3.3V~14V Input 0.59V~5.1V/10A Output

Efficiency vs Io & Vin

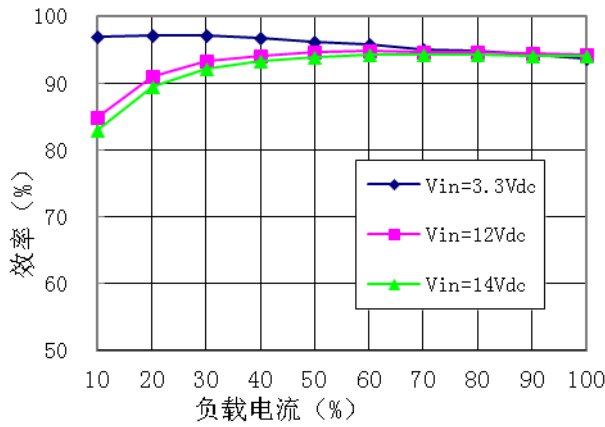

Derating (Vin=12Vdc)

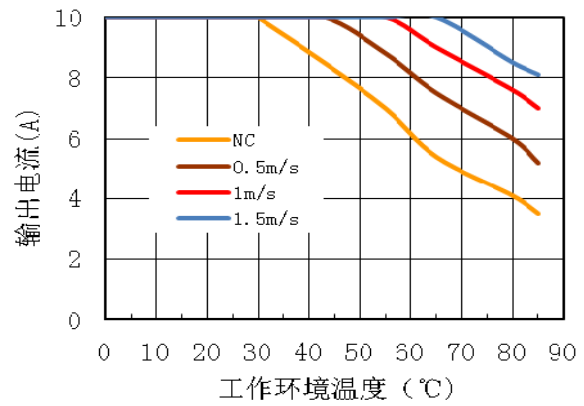

Characteristic Curves (Vo=5.0V)

Load Transient Response

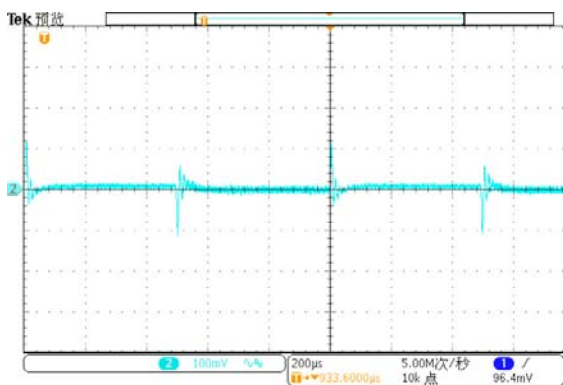

50%~100%~50% load, 0.1A/μs
 Vin=12Vdc

Output Ripple and noise

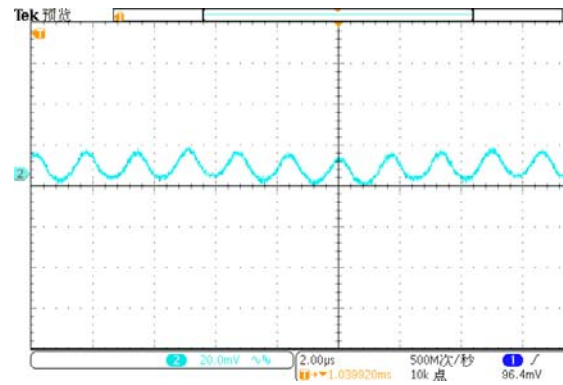

Vin=12Vdc

Output delay time

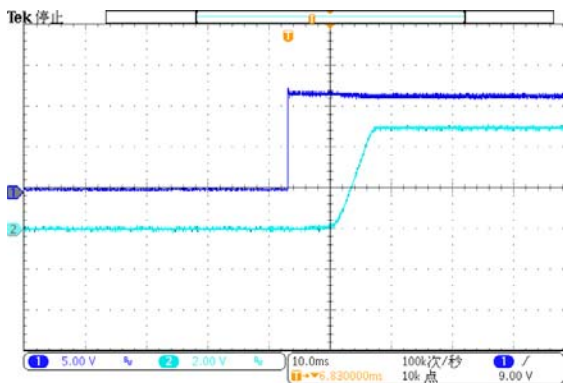

ZBK10-12BST Non-isolated DC-DC Converters
3.3V~14V Input 0.59V~5.1V/10A Output

Efficiency vs Io & Vin

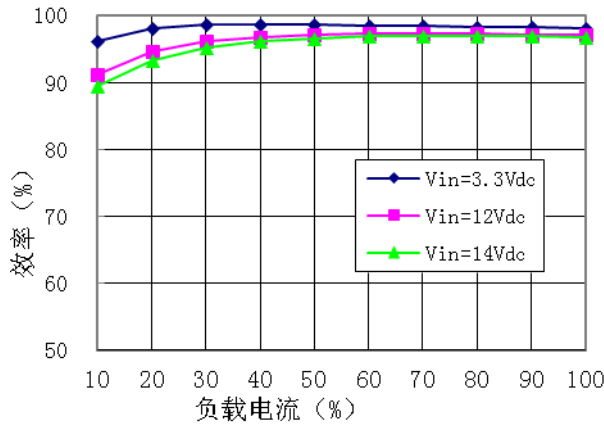

Derating (Vin=12Vdc)

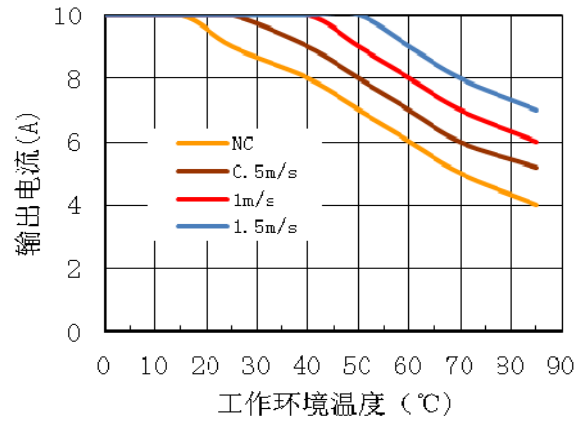

Design Considerations

Basic Connection

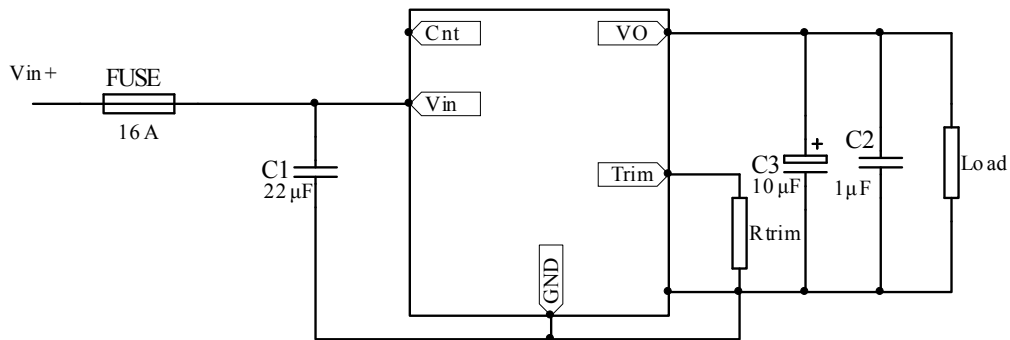

Notes: The basic connection indicates the basic requirements that the power module can provide rated output voltage and rated power only. Please refer the instruction followed for further information.

Recommended Layout

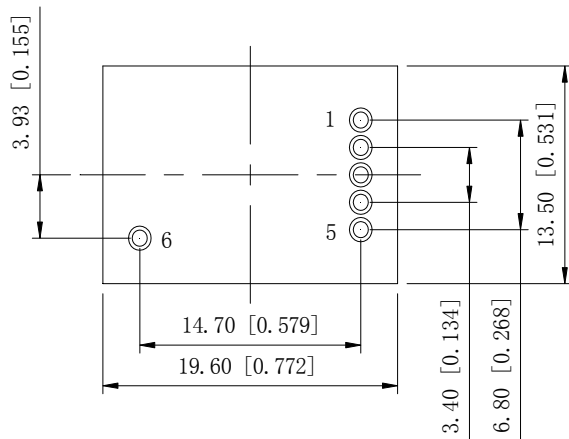

NO.	建议说明
Pad	Pad hole: Pad No.1~6 1.1 mm, Pad diameter Y 1.4mm, X 2.0mm;
Electrical	The GND planes should be placed under of the converter . Avoid routing sensitive signal or high disturbance AC signal under the converter.

Input Voltage Range

The input voltage range of the DC/DC converter is 3.3V to 14V. The input impedance of the converter looks like

ZBK10-12BST Non-isolated DC-DC Converters

3.3V~14V Input 0.59V~5.1V/10A Output

a negative resistor, which can interact with the reactance of the power bus (including any filter elements that have been added to the input of the converter), causes an unstable condition. Depending on the internal inductor's impedance, the external impedance usually should not exceed the 10% of the internal. So, the source impedance of the Power bus should be kept as low as possible.

The method to determine whether the impedance of the power bus too high or not is to decrease the converter's input voltage from higher to lower gradually, if the output voltage decreases (unstable sometime) with the lower input voltage, it will be considered the impedance too large. For further confirmation, one electrolytic capacitor can be paralleled to the converter pins after the converter shuts down (one 1μF ceramic capacitor may be required to be paralleled with the electrolytic capacitor), if the output getting better, it will be sure that the impedance is too large.

Remote Control

Remote control can be offered by setting right control voltage level (or floating) to CNT pin. The product is provided with positive logic remote control. When the level is higher than 0.8V or be left floating, the converter will be turned on. When the level is less than 0.3V, the converter will be turned off. When low voltage level is applied, the output current of the CNT is less than 1mA. When high voltage level (0.8V~14V) is applied, the input current of the CNT is less than 1mA

Due to the logic comparator is semiconductor integrated chip, they have low endurance to surge. Care should be taken to prevent CNT from surge, A TVS should be used in some cases.

External Capacitance

Unless special purpose (i.e. prolonging hold-up time, input impedance matching), the recommended input filter's capacitance ranges 47μF-220μF, which not only offers a stable system, and reduces the cost, but also lessens the inrush current when the power supplies.

When larger capacitance is required, a circuit of suppressing the inrush current is recommended when the regulator start-up and a discharge circuit is recommended when the output dropped, ensuring the reliability and safety of other equipments in the system.

Output Voltage Adjust

Resistive trim:

Change the Rtrim resistive, output voltage change from 0.59V to 5.1V :

$$R_{trim} = \frac{1.182}{(V_o - 0.591)}$$

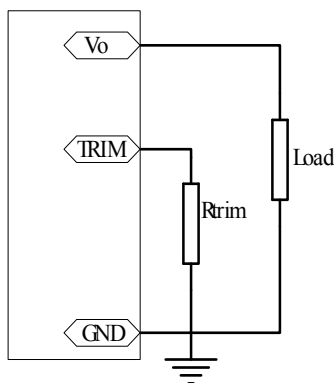

Table 1 resistive added	
output (V)	Resistive (k Ω)
0.59	open
0.9	3.825
1.2	1.941
1.8	0.978
2.5	0.619
3.3	0.436
5.0	0.268
5.1	0.262

Thermal Consideration

The converters operate in a variety of thermal environments; however, sufficient cooling should be provided to ensure reliable operation of the unit. Heat is removed by conduction, convection and radiation to the surrounding environment. For the specified ambient temperature, user can increase airflow and change the size of heatsink to improve the heat dissipating for the module with baseplate; user can only increase airflow to improve the heat dissipating for the models without heat sink. Note that the natural convection condition means that airflow is 0.05~0.1m/s.

ZBK10-12BST Non-isolated DC-DC Converters

3.3V~14V Input 0.59V~5.1V/10A Output

ESD Control

The converters are processed and manufactured in an ESD controlled environment and supplied in conductive packaging to prevent ESD damage from occurring before or during shipping. It is essential that they are unpacked and handled using an ESD control procedures. Failure to do so affects the lifetime of the converter.

Quality Statement

The converters are manufactured in accordance with ISO 9001 system requirements, in compliant with YD/T1376-2005, and are monitored 100% by auto-testing system, 100% burn in.

The warranty for the converters is 5-year.

Contact Information

*Anhui Hesion Trading Co.,Ltd.
& Beijing WiENPower Technology Co.Ltd.*

TEL:+86-551-65369069,65369067

Email: alecz@ahhesion.com

Backup:alecz@126.com

www.ahhesionpower.com