

**RAQS60-110E12K DC-DC Converters**

Input 14V~160V, Output 12V/5A, Industry Standard Quarter Brick

**Contents**

Outline Diagram ..... 1  
 Features ..... 1  
 Ordering Information ..... 1  
 Specification ..... 2  
 Characteristic Curves ..... 4  
 Design Considerations ..... 6  
     Basic Connection ..... 6  
     Recommended Layout ..... 6  
     Input Voltage Range ..... 7  
     Remote Control ..... 7  
     External Capacitance ..... 7  
     Output Voltage Adjust ..... 7  
     Over Temperature Protection ..... 8  
     Remote Sense ..... 8  
     Output Over Voltage Protection ..... 8  
     EMC Solution ..... 9  
     Thermal Consideration ..... 9  
     Safety Consideration ..... 9  
     Product Installation ..... 9  
     ESD Control ..... 9  
 Delivery Package Information ..... 10  
 Quality Statement ..... 10  
 Contact Information ..... 10

**Outline Diagram**

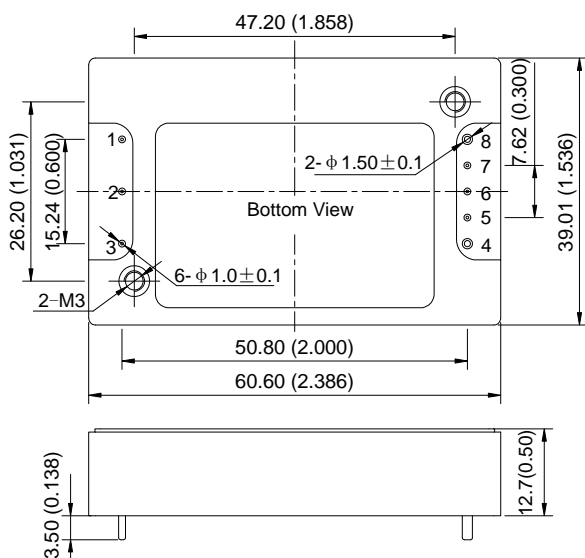

Notes: all dimensions in mm (inches)  
 Tolerances: X.X±0.5 (X.XX±0.02)  
               X.XX±0.25 (X.XXX±0.010)  
 Case material: Black flame retardant Plastic;  
 Pins: Copper alloy with gold plating;  
 Aluminum baseplate can be connected to Protective Earth pin by M3 screw.



**Features**

- ◆ Quarter Brick (60.6mm×39.01mm×12.7mm)
- ◆ Input Under Voltage Protection (10V to 13.5V turn off)
- ◆ Positive Logic Control (3.5V to 15V turn on)
- ◆ Output Over Voltage Protection (14.4V to 16.8V)
- ◆ Output Voltage Adjust Range: ±10% of the rated output voltage
- ◆ High Efficiency up to 88% (110V, full load)
- ◆ 3000Vac Isolation Voltage
- ◆ Operating Ambient Temperature -40°C to +85°C
- ◆ Operating Baseplate Temperature -40°C to +100°C
- ◆ 115°C Typ Over Temperature Protection (Baseplate Temperature)
- ◆ Conforming to the EN50155 Standard Test
- ◆ Applications: Industrial electronics & control and Rail transit & railway application

**Ordering Information**

See Contents for individual product ordering numbers.

Suffix	Description	Ordering No.
--	Shown as the specification, Positive Logic Control	RAQS60-110E12K
P	Negative Logic Control. Turn off when CNT pin is applied to 3.5~15V voltage or kept floating; Turn on when CNT pin is applied to 0~1.5V voltage	RAQ60-110E12PK

**RAQS60-110E12K DC-DC Converters**

Input 14V~160V, Output 12V/5A, Industry Standard Quarter Brick

**Pin definition:**

Pin	Symbol	Function
1	-Vin	Negative Input
2	CNT	Remote Control, turn on/off the converter without cutting off the power supply
3	+Vin	Positive Input
4	+Vo	Positive Output
5	+S	Positive Remote Sense, connected to +Vo pin when not used
6	TRIM	Output Voltage Trim, voltage be trimmed up or down by applying external resistor connected to +S or -S output
7	-S	Negative Remote Sense, connected to -Vo pin when not used
8	-Vo	Negative Output

**Specification**

Unless otherwise specified, all tests are at room temperature and standard atmosphere, pure resistive load and basic connection.

Input	Symbol	Min	Typ	Max	Unit	Conditions
Input Voltage	$V_{in}$	14	110	160	V	—
Input Current	$I_{in}$	—	—	5.6	A	—
Positive Logic Control	On	—	3.5	—	15.0	V Refer to - $V_{in}$ : Turn on when CNT floating
	Off	—	0	—	1.5	V Refer to - $V_{in}$
	Current	—	—	—	1.0	mA CNT source current when turn off
Negative Logic Control	On	—	0	—	1.5	V Refer to - $V_{in}$
	Current	—	—	—	1.0	mA CNT source current when turn on
	Off	—	3.5	—	15.0	V Refer to - $V_{in}$ : Turn off when CNT floating
	Current	—	—	—	1.0	mA CNT sink current when turn off
Start-up Delay Time	$T_{delay}$	—	10	—	ms	—
Under Voltage Threshold	$V_{UVLO}$	10	—	13.5	V	—
Under Voltage Protection Hysteresis	$\Delta V_{UVLO}$	1	—	2	V	—

Output	Symbol	Min	Typ	Max	Unit	Conditions
Output Voltage	$V_O$	11.88	12.00	12.12	V	—
Output Current	$I_{O,nom}$	—	5	—	A	—
Output Voltage Adjust Range	$V_{trim}$	10.8	—	13.2	V	$I_O \leq 5A$ $P_O \leq 60W$
Line Regulation	$S_V$	—	—	$\pm 0.2$	% $V_O$	$V_{in}: 14V \sim 160V, I_O = 5A$
Load Regulation	$S_I$	—	—	$\pm 0.5$	% $V_O$	$V_{in} = 110V, I_O: 0A \sim 5A$
Output Over Voltage Protection Set Point	$V_{ov,set}$	14.4	—	16.8	V	—
Output Over Current Protection Range	$I_{O,lim}$	5.5	—	11	A	—
Output Short-circuit Protection	Hiccup mode, automatic recovery					
Rise Time	$T_{rise}$	—	10	—	ms	$I_{O,nom}$ , pure resistive load

**RAQS60-110E12K DC-DC Converters**

Input 14V~160V, Output 12V/5A, Industry Standard Quarter Brick

Continue

Output		Symbol	Min	Typ	Max	Unit	Conditions
Peak to Peak Ripple and Noise		$\Delta V_{pp}$	—	—	200	mV	20MHz bandwidth, when testing, Output equipped with 220 $\mu$ F aluminum electrolytic capacitor and 22 $\mu$ F ceramic capacitor
Output Overshoot		$V_{TO}$	0	—	1.2	V	—
Capacitive Load		$C_O$	0	—	4200	$\mu$ F	—
Remote Sense Compensation Range		$V_{sense}$	0	—	0.5	V	+S and -S twisted Pair, length is less than 20cm
Load Transient	Recovery Time	$t_{tr}$	—	—	400	$\mu$ s	25%~50%~25% $I_{O,nom}$ or 50%~75%~50% $I_{O,nom}$ ; 0.1A/ $\mu$ s
	Voltage Deviation	$\Delta V_{tr}$	—	—	$\pm 600$	mV	

General	Symbol	Min	Typ	Max	Unit	Conditions
Efficiency	$\eta$	—	88	—	%	$V_{in}=110V, I_{O,nom}$
Switching Frequency	$f_s$	—	230	—	kHz	—
Isolation Resistance	$R_{iso}$	50	—	—	M $\Omega$	—
Isolation Voltage	$V_{iso}$	3000	—	—	Vac	Input to output, leakage current $\leq 5mA$
		1500	—	—	Vac	Input to case, leakage current $\leq 5mA$
		1500	—	—	Vac	Output to case, leakage current $\leq 5mA$
		Short all the pins on the input side during the test, and short all the pins on the output side				
Vibration and Shock	Meets EN50155					
MTBF	—	—	$2 \times 10^6$	—	h	BELLCORE TR-332
Operating Ambient Temperature	$T_A$	-40	—	85	$^{\circ}C$	See Derating Curve
Operating Baseplate Temperature	$T_C$	-40	—	100	$^{\circ}C$	—
Storage Temperature	$T_S$	-55	—	+125	$^{\circ}C$	—
Temperature Coefficient	$S_T$	—	—	$\pm 0.02$	%/ $^{\circ}C$	—
Over Temperature Protection Reference Point	$T_{ref}$	—	115	—	$^{\circ}C$	Baseplate Temperature
Over Temperature Protection Hysteresis	$\Delta T_{ref}$	—	10	—	$^{\circ}C$	
Thermal resistance	$R_{\theta CA}$	—	9.8	—	$^{\circ}C/W$	Natural Convection Without Heatsink
	$R_{\theta CA}$	—	7.6	—	$^{\circ}C/W$	Natural Convection With Heatsink
	$R_{\theta CA}$	—	8.7	—	$^{\circ}C/W$	100 LFM Convection Without Heatsink
	$R_{\theta CA}$	—	7.0	—	$^{\circ}C/W$	100 LFM Convection With Heatsink
	$R_{\theta CA}$	—	7.1	—	$^{\circ}C/W$	200 LFM Convection Without Heatsink
	$R_{\theta CA}$	—	4.6	—	$^{\circ}C/W$	200 LFM Convection With Heatsink

## RAQS60-110E12K DC-DC Converters

Input 14V~160V, Output 12V/5A, Industry Standard Quarter Brick

Continue

General	Symbol	Min	Typ	Max	Unit	Conditions
Thermal resistance	$R_{\theta CA}$	—	6.5	—	°C/W	300 LFM Convection Without Heatsink
	$R_{\theta CA}$	—	4.0	—	°C/W	300 LFM Convection With Heatsink
	$R_{\theta CA}$	—	6.2	—	°C/W	400 LFM Convection Without Heatsink
	$R_{\theta CA}$	—	3.1	—	°C/W	400 LFM Convection With Heatsink
Hand Soldering	Maximum soldering Temperature < 425°C, and duration < 5s					
Wave Soldering	Maximum soldering Temperature < 255°C, and duration < 10s					
Weight	—	—	60	—	g	—
EMC Specifications		Standards & Conditions				Level
EMI Conducted Emission	EN55032	(See Page 9)				Class A
Surge Immunity	IEC/EN61000-4-5 GB/T 17626.5	line to line( $\pm 1kV/2\Omega$ ); line to ground( $\pm 2kV/12\Omega$ ) (See Page 9)				B
Fast Transient	IEC/EN61000-4-4 GB/T 17626.4	$\pm 2kV(5/50ns, 5kHz)$ (See Page 9)				A

### Characteristic Curves

Load Transient Response

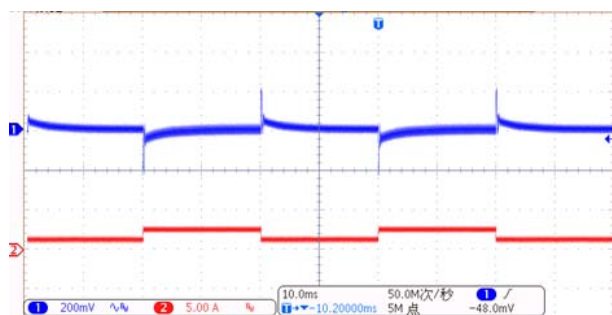

Load change: 25%~50%  
~25%  $I_{O,nom}$ , 0.1A/ $\mu s$   
 $V_{in}=110V_{dc}$   
Trace1: 0.2V/div  
Trace2: 5A/div  
Time scale: 10ms/div

Load Transient Response

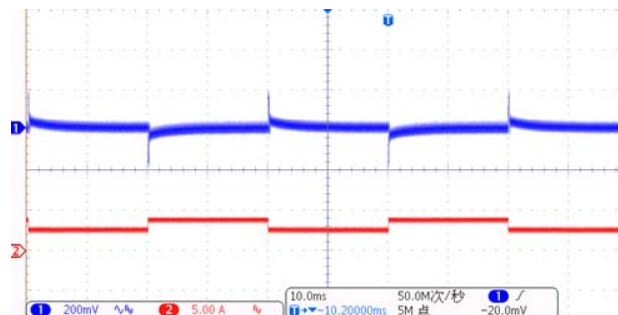

Load change: 50%~75%  
~50%  $I_{O,nom}$ , 0.1A/ $\mu s$   
 $V_{in}=110V_{dc}$   
Trace1: 0.2V/div  
Trace2: 5A/div  
Time scale: 10ms/div

Output Ripple and noise

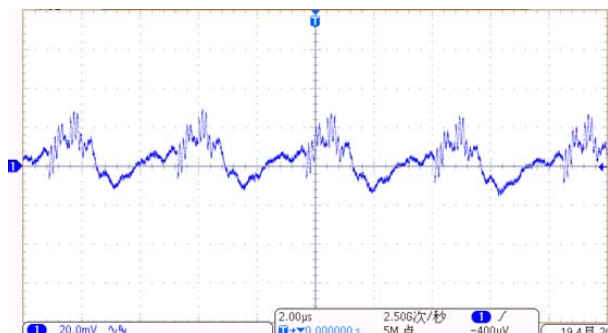

$V_{in}=110V, I_O=5A$

Start-up Delay Time

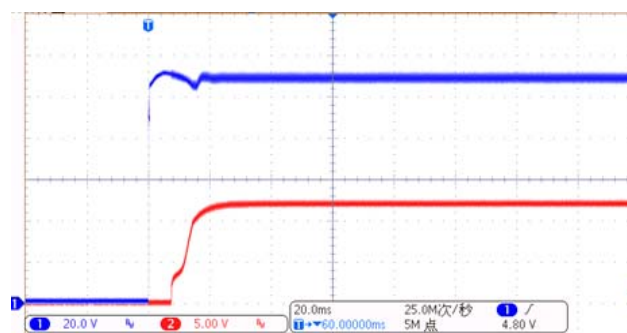

$V_{in}=110V, I_O=5A$

**RAQS60-110E12K DC-DC Converters**

Input 14V~160V, Output 12V/5A, Industry Standard Quarter Brick

**Rise Time**

**Turn-off**

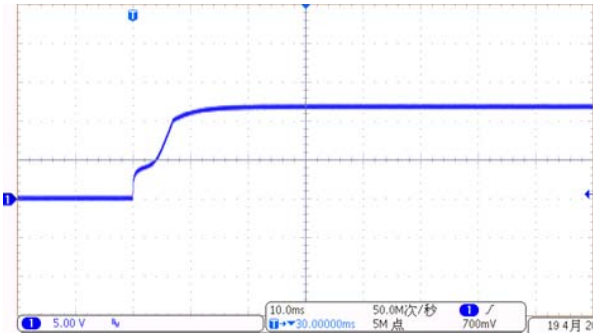

Vin=110V, Io=5A

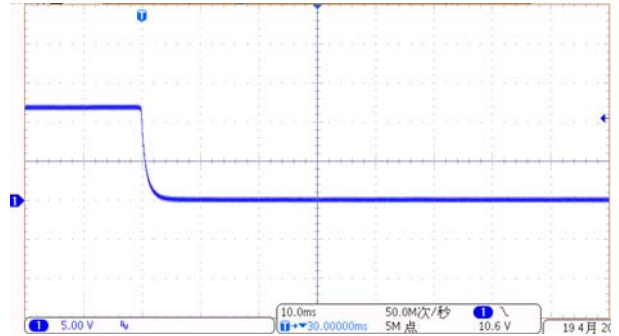

Vin=110V, Io=5A

**Derating curve with 0.45" HS Heatsink**

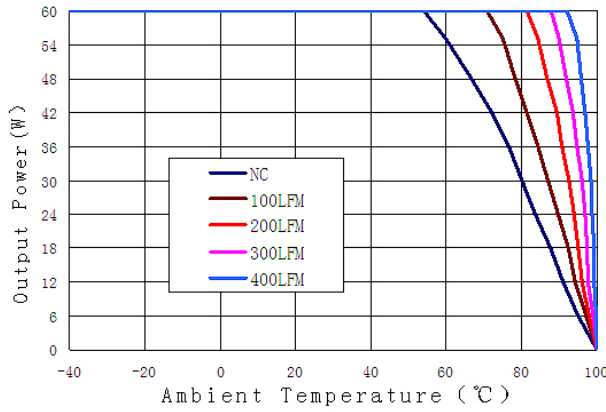

**Derating curve without Heatsink**

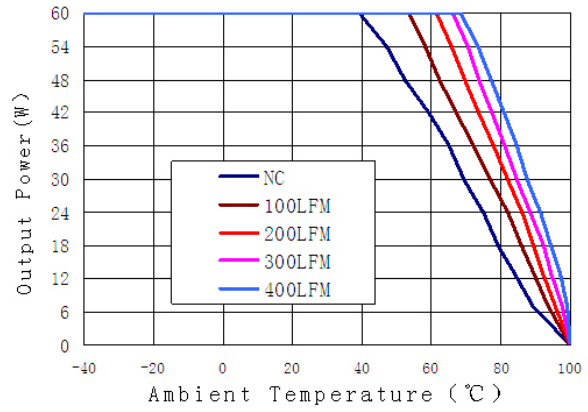

**Efficiency vs Load Current**

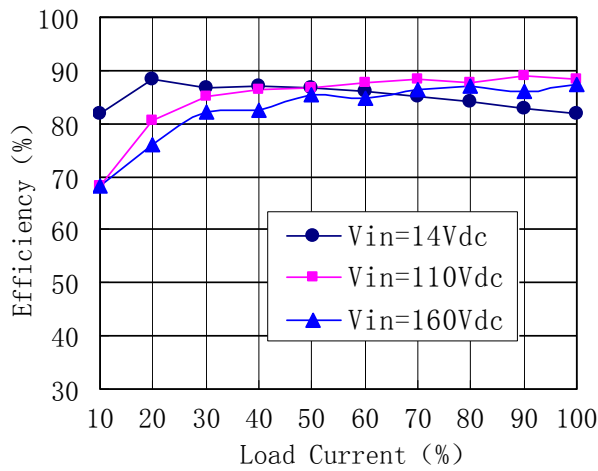

## RAQS60-110E12K DC-DC Converters

Input 14V~160V, Output 12V/5A, Industry Standard Quarter Brick

### Design Considerations

#### Basic Connection

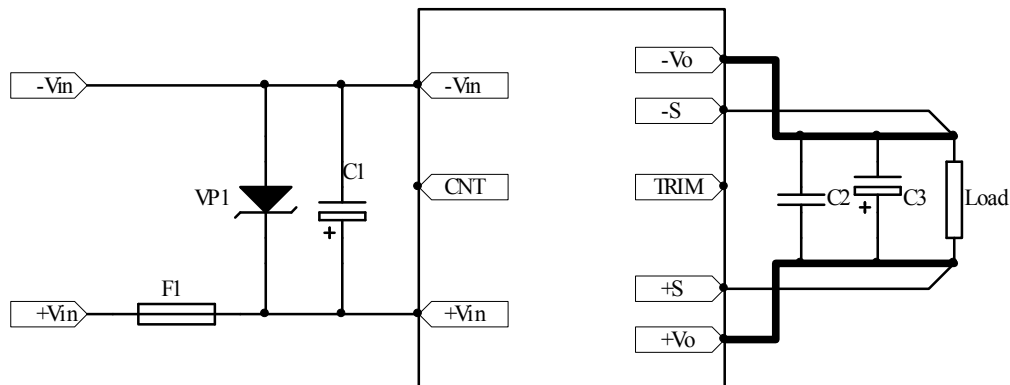

#### parameter declaration:

Part No.	Components	Part No.	Components	Part No.	Components
F1	15A Fuse	C1	100 $\mu$ F Aluminum Electrolytic Capacitor	C3	220 $\mu$ F 100 $\mu$ F Aluminum Electrolytic Capacitor
VP1	P6KE180A TVS	C2	22 $\mu$ F Ceramic Capacitor	—	—

#### Recommended Layout

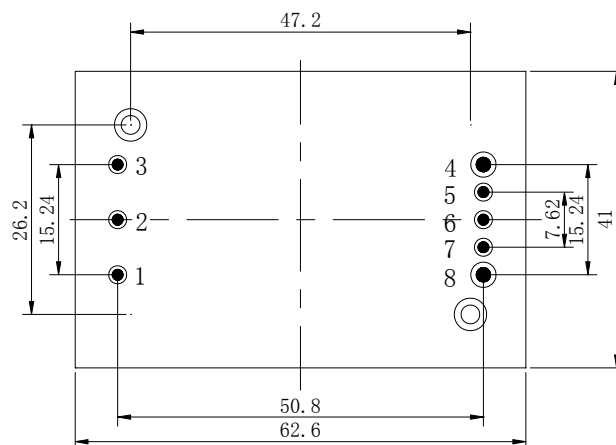

NO.	Recommendation & Notes
Pad Design	4 and 8 Pad holes: 1.9 mm, pad diameter including hole: 3.5mm in the X direction, 2.3mm in the Y direction; the rest are 1.5mm, pad diameter including hole: 2.5 mm in the X direction, 2.1mm in the Y direction. Fixed diagonal studs is applied to improve the shock resistance. The diameter of the diagonal fixed holes is 3.6mm. To ensure insulation resistance, it is recommended to select the M3 cross slotted head screw with GB823-88, and make slots with a width of at least 1.5mm between the fixed holes and the pad of pins.
Safety	Isolated Converters, care to the spacing between input and output, input and protective ground, output and protective ground
Electrical	The Vin(-) and Vo(-) planes should be placed under of the converter separately. Avoid routing sensitive signal or high disturbance AC signal under the converter



**RAQS60-110E12K DC-DC Converters**

Input 14V~160V, Output 12V/5A, Industry Standard Quarter Brick

**Input Voltage Range**

The input voltage range of the DC/DC converter is 14V~160V. The input impedance of the converter looks like a negative resistor, which can interact with the reactance of the power bus (including any filter elements that have been added to the input of the converter), causes an unstable condition.

The method to determine whether the impedance of the power bus too high or not is to decrease the converter's input voltage from higher to lower gradually, if the output voltage decreases (unstable sometime) with the lower input voltage, it will be considered the impedance too large. For further confirmation, one electrolytic capacitor can be paralleled to the converter pins after the converter shuts down (one 1 $\mu$ F ceramic capacitor may be required to be paralleled with the electrolytic capacitor), if the output getting better, it will be sure that the impedance is too large.

**Remote Control**

Remote control can be offered by setting right control voltage level (floating, high resistance) to CNT pin. RAQS60-110E12K is provided with positive logic remote control. The circuit diagram is shown as "Internal Circuit Diagram for Positive Logic Control". When the pin is left floating or the voltage of the pin is 3.5V-15V, the converter will turn on. When the level is less than 1.5V, the converter will turn off.

Due to the logic comparator is semiconductor integrated chip, they have low endurance to surge. Care should be taken to prevent CNT from surge, A TVS should be used in some cases.

RAQS60-110E12PK is provided with negative logic remote control. It has the same characteristic as RAQS60-110E12K, except control logic. When the pin is left floating or the voltage of the pin is 3.5V-15V, the converter will turn off. When the level is less than 1.5V, the converter will turn on. Like positive logic control converters, care should be taken to prevent CNT from surge.

In some applications, extra controls will be designed for the converter in user's PCB, such as output short circuit protection, over voltage protection, under voltage protection, synchronous control to the converter output voltage, and so on, remote control will give you help. The controls can be achieved by external circuit applied to the CNT pin.

When the signal from the system is beyond 3.5V-15V, or it can be enabled only within a very narrow control level, the aux circuit will be required. Please contact us for more information.

**External Capacitance**

Unless special purpose (i.e. prolonging hold-up time, input impedance matching), the recommended input filter's capacitance ranges 100 $\mu$ F to 330 $\mu$ F, which not only offers a stable system, and reduces the cost, but also lessens the inrush current when the power supplies.

When larger capacitance is required, a circuit of suppressing the inrush current is recommended when the regulator start-up and a discharge circuit is recommended when the output dropped, ensuring the reliability and safety of other equipments in the system.

The recommended output filter's capacitance is at least 220 $\mu$ F (less than the maximum Capacitive Load of the product), which can reduce the ripple noise.

**Output Voltage Adjust**

The converters have an Output Voltage adjust pin (Trim). This pin can be used to adjust the output voltage above or below Output voltage initial setting. The maximum value of the trimmed up is 10%, even +S and -S pins are used to compensate the voltage simultaneously, the sum of the trimmed up and the compensation should not be more than 10%, or the characteristics will not be assured in compliant with the specification, even the over voltage protection may be triggered. The output power can not exceed 60W at increased output voltages, and the output current can not exceed 5A. When the trim pin is not used, it should be floated.

External circuit is connected as the figure shown, the resistance is calculated as the formula below, please note that the formula will be invalid when  $R_{Trim-up}$ ,  $R_{Trim-down}$  are used simultaneously, users adjust the value based on the resistance applied.

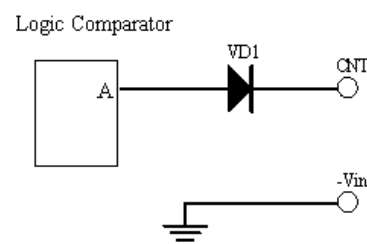

**Internal Circuit Diagram For Positive Logic Control**

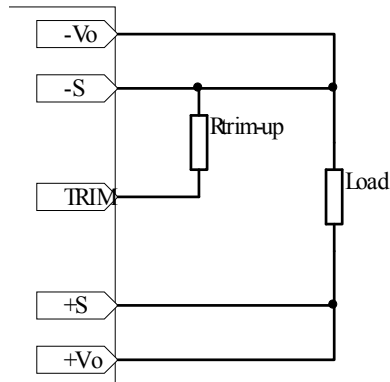

**Connection for Trimming Up**

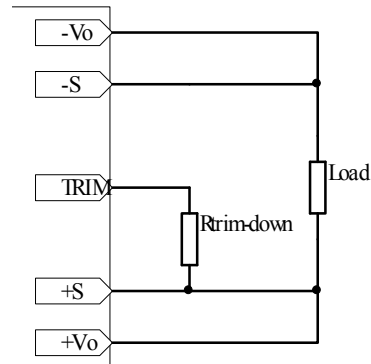

**Connection of Trimming Down**

Resistance for trimming up:  $R_{Trim-up} = \left( \frac{23.6}{\Delta V} - 6.49 \right) (k\Omega)$

Resistance for trimming down:  $R_{Trim-down} = \left( \frac{9.44 \times (V_o - \Delta V_o - 2.5)}{\Delta V_o} - 6.49 \right) (k\Omega)$

$R_{Trim-up}$ 、 $R_{Trim-down}$  :Resistance for trimming up or down, Unit:kΩ;

$\Delta V_o$ : Change rate, divide output voltage by rated output voltage;

$V_o$ : rated output voltage.

For example: trimmed down voltage to 11V,  $\Delta V_o = 1V$ , then  $R_{Trim-down} = 9.44 \times (12 - 1 - 2.5) / 1 - 6.49 = 73.75 (k\Omega)$ , it can be taken as 70kΩ.

**Over Temperature Protection**

The over temperature protection feature is used to protect the converter, and the sensor locates in the baseplate. If the temperature of the baseplate exceeds the threshold of 115°C, the converter will shut down.

The converter will stop until safe operating temperature is restored. Hysteresis temperature between OTP trig point and restart is approx 10°C. Time between OTP and restart is dependent on cooling of the regulator ,and radiation to the surrounding environment. If the surrounding environment does not change, restart will work cycle by cycle.

**Remote Sense**

The remote sense can be used to compensate for the voltage drop between the output pins of the converter and the load input pins by +S、-S pins. The +S and -S pins should be connected to the input pins of the load respectively. The remote sense circuit will compensate for maximum 0.5 voltage drop between the sense voltage and the voltage at the output pins.

The anti-interference design should be considered when the +S、-S pins are connected to the pins to be compensated. The +S、-S traces should be located close to a ground trace or ground plane, and the area they surrounded should be minimized (just for electrical isolation); If cable connection presents, twisted pair wires should be used, EMI core are equipped with the twisted pair wires to reduce common mode noise when necessary, the sense leads should not be longer than 200mm,or the system characteristics may not be assured.

The sense leads only can carry very little current, and are not used for converter power output. Care should be taken in operation to avoid damaging the converter.

**Output Over Voltage Protection**

The converter is designed with clamped over voltage protection, when output voltage exceeds 14.4V to 16.8V ( the set point is between 14.4V to 16.8V, there is the difference based on the specific parameters, but not beyond the range), the output voltage will be clamped and attempt to restart periodically. Be advised that to shut down the converter by using remote control if it can not be repaired timely. Avoid the continuous resetting of the unit because that will damage the converter.



**RAQS60-110E12K DC-DC Converters**

Input 14V~160V, Output 12V/5A, Industry Standard Quarter Brick

**EMC Solution**

Recommendation circuit for EMI Conducted emission、Fast transient/burst immunity、Surge immunity.

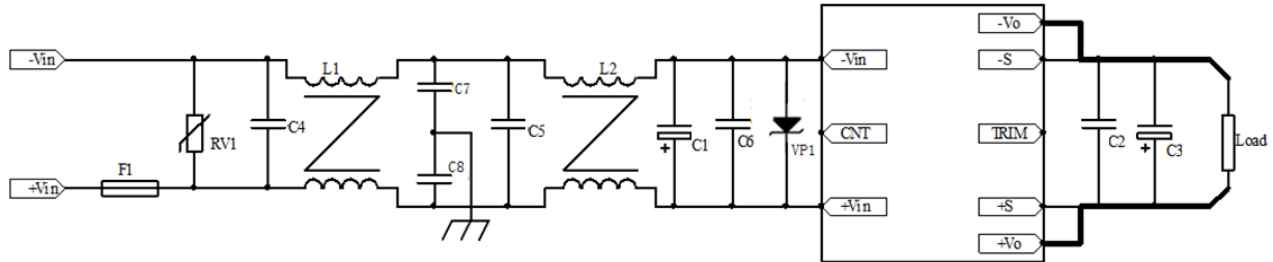

**parameter declaration:**

Part No.	Components	Part No.	Components
F1	15A Fuse	C2	22μF ceramic Capacitor
RV1	180KD14 Voltage Dependent Resistor	C3	220μF Aluminum Electrolytic Capacitor
C4,C5,C6	1μF Film Capacitors	L1,L2	1.5mH Common Mode Inductors
VP1	180V TVS	C7,C8	1nF/400VAC Safety Capacitors
C1	100μF Aluminum Electrolytic Capacitor		

**Thermal Consideration**

The converters operate in a variety of thermal environments,however, sufficient cooling should be provided to ensure reliable operation of the unit. Heat is removed by conduction, convection and radiation to the surrounding environment. The air tunnel should be considered for forced air cooling, to avoid heated air be hindered or forming swirl.When heatsink used, it should be attached the converter closely, through double-side thermal conductivity insulation adhesive or thermal conductivity silicone for heat exchange.

For the specified ambient temperature, user can increase airflow and change the size of heatsink to improve the heat dissipating for the module with baseplate,neither airflow nor heatsink ,the derating curves should be referred or external heat dissipation measures.

**Safety Consideration**

The converter, as one component for the end user, should be installed into the equipment, and all the safety considerations are achieved under certain condition. It is required to meet safety requirements in system design for the user. The converter output is considered SELV, and the expected input is considered TNV2,the primary to secondary is reinforced insulation to EN60950.

To avoid fire and be protected when short circuit occurred, it is recommended that a fast blow fuse with rating 2.5-3 times of converter continuous input peak current is used in series at the input terminal.(Inrush current suppression circuit is required for greater filter capacitance at input terminal, or it will result in the misoperation of the fuse).

**Product Installation**

The product can be installed in user board, suggest using M3 cross slotted head screw with GB823-88 to fix the product in user board, in order to enhance the bearing ability when impact and vibration coming. Note that, when you hammer the product using screws, this product shall be first fixed, again a needle pin welding, prevent strain soldered dot. Moreover the biggest torque of fastening screw cannot exceed 0.6N.m,otherwise it will likely damage, the structural related to studs.

Metal surface of this product structured by aluminum PCB which has good thermal conductivity, mapping the overburden with heat conduction medias or thermal gaskets, then install proper radiator.

Proper radiator and flows through radiator wind will greatly enhances products cooling capacity. When you install radiator, you should be paid attention to the length of the bolt, ensure that has no relevant relatives with the screws fixed on PCB.

**ESD Control**

The converters are processed and manufactured in an ESD controlled environment and supplied in conductive

**RAQS60-110E12K DC-DC Converters**

Input 14V~160V, Output 12V/5A, Industry Standard Quarter Brick

packaging to prevent ESD damage from occurring before or during shipping. It is essential that they are unpacked and handled using an ESD control procedures. Failure to do so affects the lifetime of the converter.

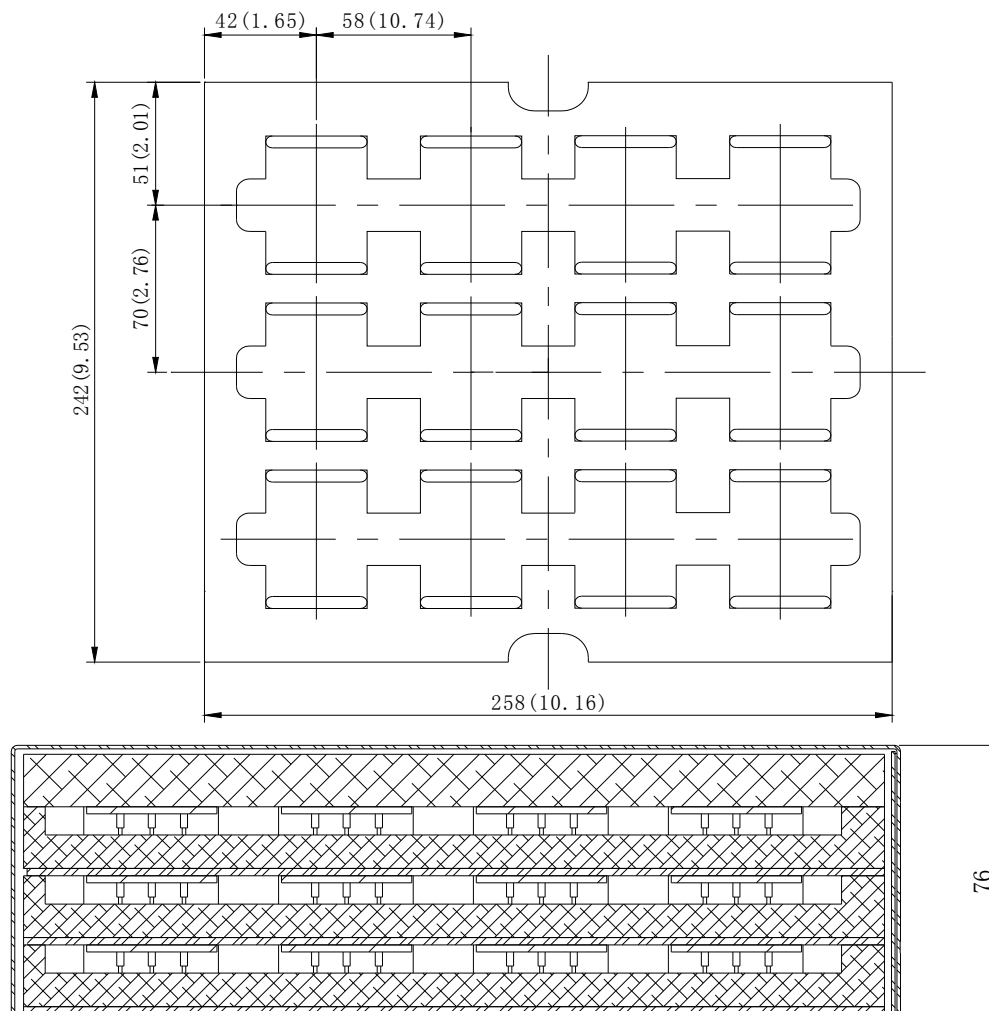
**Delivery Package Information**

Package material is multiple wall corrugated, internal material is anti-static foam, it's surface resistance is from  $10^5 \Omega$  to  $10^{12} \Omega$ . Tray capacity:  $3 \times 12 = 36$  PCS/box, Tray weight: 2.5kg; Carton capacity:  $4 \times 36 = 144$  PCS, Carton weight: 10kg.

**Quality Statement**

The converters are manufactured in accordance with ISO 9001 system requirements, in compliant with EN50155, and are monitored 100% by auto-testing system, 100% burn in.

The warranty for the converters is 5-year.

**Contact Information**

Anhui Hesion Trading Co.,Ltd.  
& Beijing Yihongtai Technology Dev.Co.,Ltd

TEL: +86-551-65369069,65369067

Email: [alecz@ahhesion.com](mailto:alecz@ahhesion.com)

Backup:[alecz@126.com](mailto:alecz@126.com)

[www.ahhesionpower.com](http://www.ahhesionpower.com)