

WLD30-48S12L DC-DC Converter

Input 18V~75V Output 12V/2.5A 1in.×2 in. Industry Standard Size

Contents

Outline Diagram.....1
 Features1
 Specifications2
 Characteristic Curves3
 Design Considerations4
 Basic Connection4
 Recommended Layout5
 Input Voltage Range5
 External Capacitance.....5
 Remote Control5
 Output Voltage Adjust6
 Thermal Consideration.....6
 Safety Consideration6
 EMC Consideration.....6
 Series and Parallel Operation7
 Cleaning Notice7
 Delivery Package Information7
 Quality Statement.....7
 Contact Information7



Outline Diagram

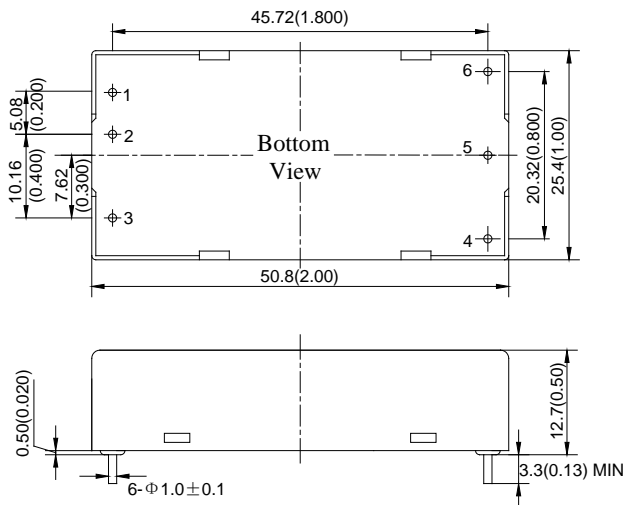

Features

- ◆ 1in.×2in. Industry Standard Size (50.8 mm×25.4 mm×12.7 mm)
- ◆ Wide Input Voltage (18V~75V)
- ◆ Positive Logic Control (3.5V~15V turn on)
- ◆ Output Voltage Adjust Range:±10 % of the rated output voltage
- ◆ Output Short-circuit Protection, hiccup, auto-recovery
- ◆ High Efficiency,87% typ.(Input 48V, full load)
- ◆ 1600Vdc Min. Isolation Voltage
- ◆ Operating Case Temp:-40 ℃ to +105 ℃
- ◆ Applications: Telecom / Datacom system equipments and Railway & Rail transit ,Industrial control equipments and Instrument.

Pin Description		
S/N	Symbol	Function
1	+Vin	Positive Input Voltage
2	-Vin	Negative Input Voltage
3	CNT	Remote Control Pin
4	TRIM	Output Voltage Adjust
5	-Vo	Negative Output Voltage
6	+Vo	Positive Output Voltage

Notes:
Case material: Aluminum, black; Pin material: brass with gold-plating Notes: all dimensions in mm(inches) Tolerance: X.Xmm:±0.5 (X.XX:±0.020) X.XX mm:±0.25 (X.XXX:±0.010)

WLD30-48S12L DC-DC Converter

Input 18V~75V Output 12V/2.5A 1in.×2 in. Industry Standard Size

Specifications

Unless otherwise specified, all tests are at room temperature and standard atmosphere, pure resistive load.

Input		Symbol	Min	Typ	Max	Unit	Conditions
Input Voltage		V_{in}	18	48	75	V	—
Input Current		I_{in}	—	—	2.00	A	$V_{in}=18V, I_o=2.5A$
Input Idling Current		$I_{in,nl}$	—	—	30	mA	$V_{in}=18V, I_o=0A$
Positive Logic Remote Control	ON	—	3.5	—	15.0	V	Relative to $-V_{in}$; Turn on when CNT floating
	Current	—	—	—	0.5	mA	CNT sink current when turn on
	OFF	—	0	—	1.5	V	Relative to $-V_{in}$
	Current	—	—	—	1.0	mA	CNT source current when turn off
Under Voltage Threshold		V_{UVLO}	14.5	—	17.5	V	—
Start-up Delay Time		T_{delay}	—	6	—	ms	—

Output		Symbol	Min	Typ	Max	Unit	Conditions
Output Voltage		V_o	11.88	12.00	12.12	V	—
Output Current		I_o	0	—	2.5	A	—
Output Voltage Adjust Range		V_{trim}	10.8	—	13.2	V	$P_o \leq 30W, I_o \leq 2.5A$
Line Regulation		S_V	—	—	± 0.2	% V_o	$V_{in}: 18V \sim 75V, I_o = 2.5A$
Load Regulation		S_I	—	—	± 0.5	% V_o	$V_{in}=48V, I_o: 0A \sim 2.5A$
Current Limit Inception		$I_{o,lim}$	110	—	180	% $I_{o,max}$	—
Over-Shoot		V_{TO}	0	—	1.2	V	—
Output Short-circuit Protection		automatic recovery					
Peak to Peak Ripple and Noise		ΔV_{pp}	—	—	100	mV	20MHz bandwidth
Rise Time		T_{rise}	—	8.0	—	ms	$V_{in}=48V, I_{o,max}$, Pure resistive load
Capacitive Load Range		C_o	0	—	2200	μF	—
Load Transient	Recovery Time	t_{tr}	—	—	200	μs	Load change: 25% ~ 50% ~ 25% & 50% ~ 75% ~ 50% Current change: 0.1A/ μs
	Voltage Deviation	ΔV_{tr}	—	—	± 480	mV	

General		Symbol	Min	Typ	Max	Unit	Conditions
Efficiency		η	—	87	—	%	$V_{in}=48V, I_{o,max}$
Switching Frequency		f_s	—	290	—	kHz	—
Isolation Resistance		R_{iso}	50	—	—	M Ω	—
Isolation Voltage		V_{iso}	1600	—	—	Vdc	Input to Output
MTBF		—	—	2×10^6	—	h	BELLCORE TR-332
Operating Case Temperature		—	-40	—	105	$^{\circ}C$	See Natural Cooling Derating

WLD30-48S12L DC-DC Converter

Input 18V~75V Output 12V/2.5A 1in.×2 in. Industry Standard Size

Continue

General	Symbol	Min	Typ	Max	Unit	Conditions
Storage Temperature	-	-55	-	125	°C	—
Temperature Coefficient	S_T	-	-	±0.02	%/°C	—
Hand Soldering	Maximum soldering Temperature < 425 °C, and duration < 5s					
Wave Soldering	Maximum soldering Temperature < 255 °C, and duration < 10s					
Weight	-	-	30	-	g	—

EMC Specifications	Standards & Conditions		Level
EMI Conducted Emission	EN55032		Class A
	EN55032	(See Page 7)	Class B
Surge Immunity	IEC/EN61000-4-5 GB/T 17626.5	line to line(±1kV/2Ω); line to ground(±1kV/12Ω) (See Page 7)	A
Fast Transient	IEC/EN61000-4-4 GB/T 17626.4	±2kV(5/50ns, 5kHz) (See Page 7)	A

Characteristic Curves

Load Transient Response

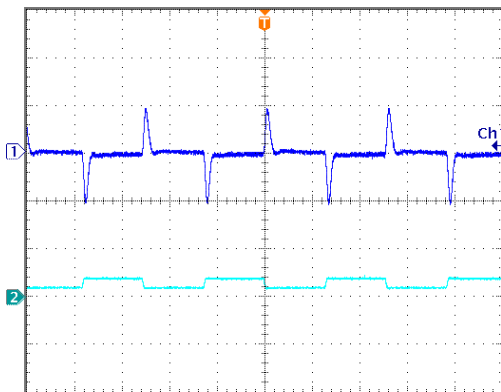

Load change:25% ~ 50% Trace1: 200mV/div
~25% $I_{o,nom}$, 0.1A/μs Trace2: 3A/div
 V_{in} =48Vdc Time scale: 0.4ms/div

Load Transient Response

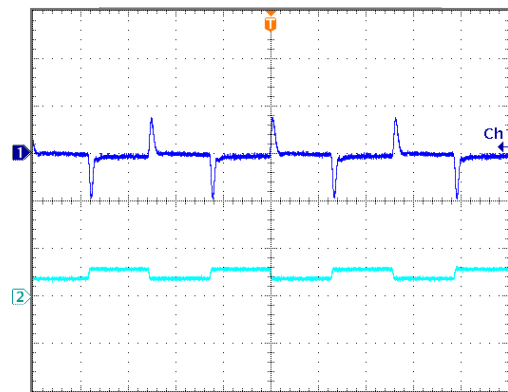

Load change:50% ~ 75% Trace1: 200mV/div
~50% $I_{o,nom}$, 0.1A/μs Trace2: 3A/div
 V_{in} =48Vdc Time scale: 0.4ms/div

Output Ripple

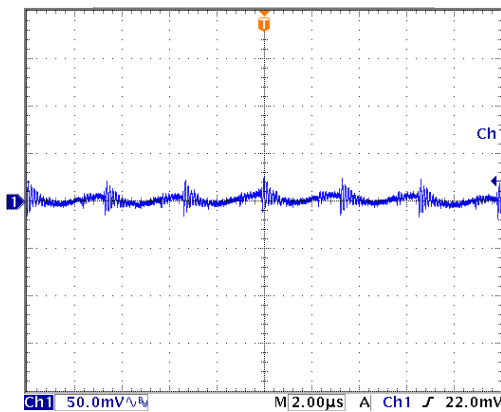

V_{in} =48V, I_o =2.5A

Start-up Delay Time

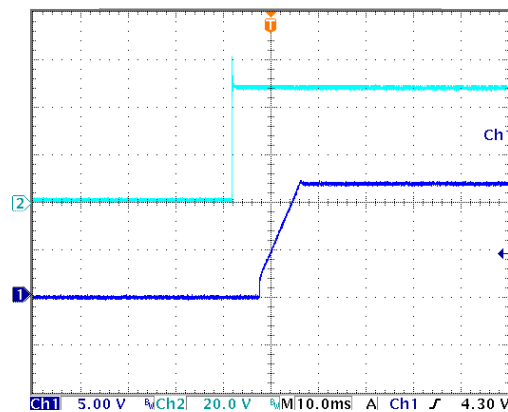

V_{in} =48V, I_o =2.5A

WLD30-48S12L DC-DC Converter

Input 18V~75V Output 12V/2.5A 1in.×2 in. Industry Standard Size

Rise Time

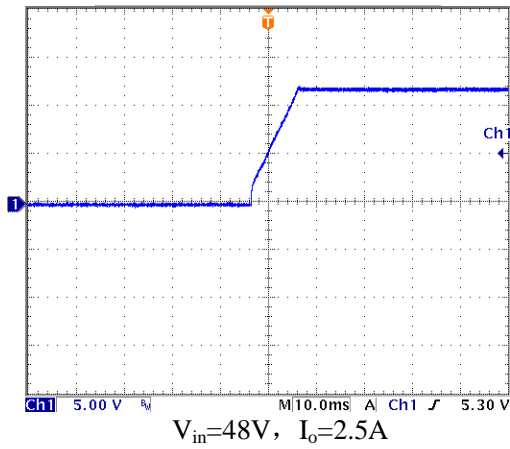

Turn-off

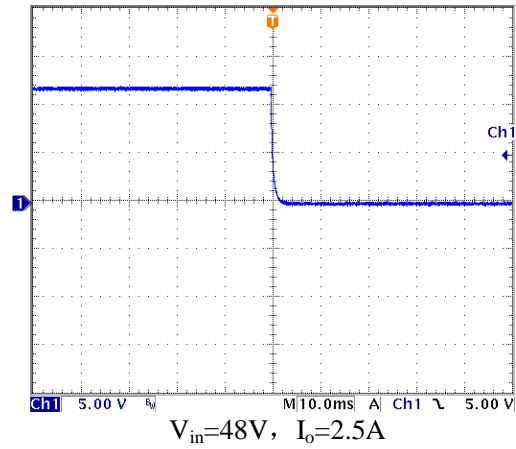

Temperature Derating Curve

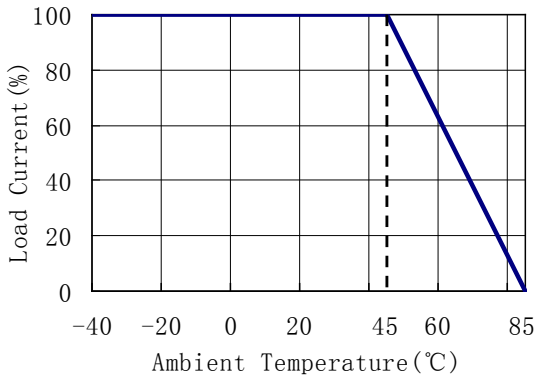

Efficiency vs. Io & Vin

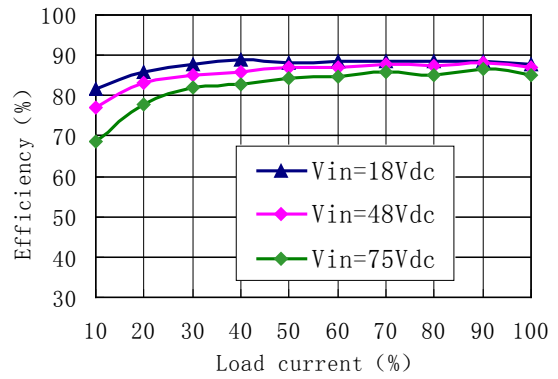

Design Considerations

Basic Connection

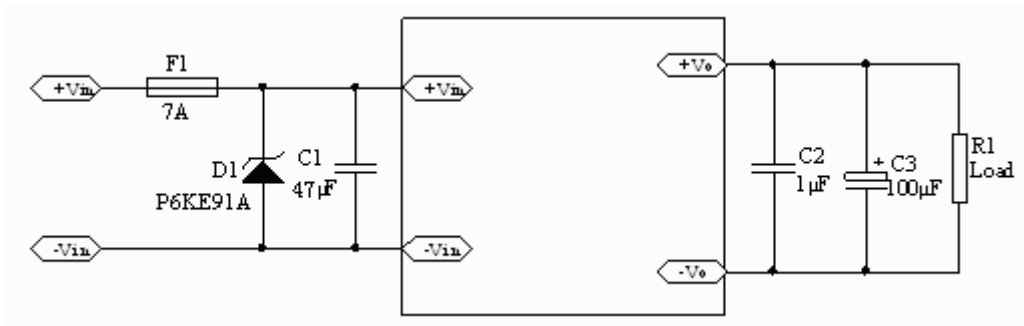

Notes: Please see the application information followed for the further information.

WLD30-48S12L DC-DC Converter

Input 18V~75V Output 12V/2.5A 1in.×2 in. Industry Standard Size

Recommended Layout

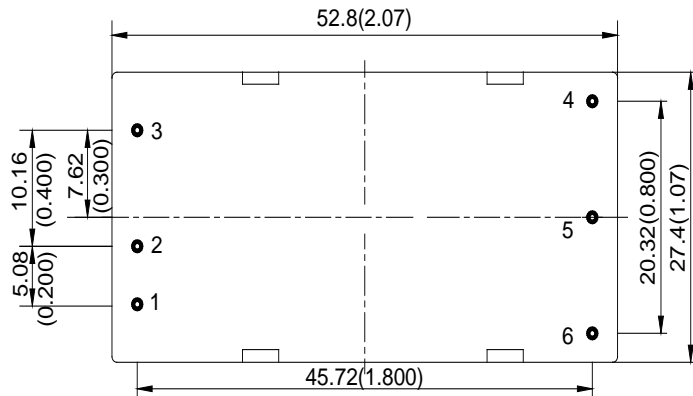

NO.	Recommendation & Notes
Pad Design	Pad holes 1~6:1.2mm, pad diameter including hole:2.5mm
Mounting Direction	heatsink face up, for natural convection
Safety	Isolated Converters, care to the spacing between input and output
Electrical	The Vin(-) and Vo(-) planes should be placed under of the converter separately. Avoid routing sensitive signal or high disturbance AC signal under the converter

Input Voltage Range

The input voltage range of the DC/DC converter is 18V~75V. The input impedance of the converter looks like a negative resistor, which can interact with the reactance of the power bus (including any filter elements that have been added to the input of the converter), causes an unstable condition.

External Capacitance

Unless special purpose (i.e. prolonging hold-up time, input impedance matching), the recommended input filter’s capacitance ranges 47μF to 220μF, which not only offers a stable system, and reduces the cost, but also lessens the inrush current when the power supplies.

When larger capacitance is required, a circuit of suppressing the inrush current is recommended when the regulator start-up and a discharge circuit is recommended when the output dropped, ensuring the reliability and safety of other equipments in the system.

Remote Control

Remote control can be offered by setting right control voltage level (floating , high resistance)to CNT pin. When the level is higher than 3.5V or be left floating, the converter will turn on. When the level is less than 1.5V , the converter will turn off.

WLD30-48S12L is provided with positive logic remote control. The circuit diagram is shown as “Internal Circuit Diagram for Positive Logic Control”. when low level applied, the CNT source current is less than 1mA.due to VD1 is signal diode, and the logic comparator is semiconductor integrated chip with low resistance to surge. Care should be taken to prevent CNT from surge, like application of TVS.

In some applications, extra controls will be designed for the converter in user’s PCB, such as output short circuit protection, over voltage protection, under voltage protection, synchronous control to the converter output voltage, and so on, remote control will give you help. The controls can be achieved by external circuit applied to the CNT pin.

When the signal from the system is beyond 3.5V~15V, or it can be enabled only within a very narrow control level, the aux circuit will be required.

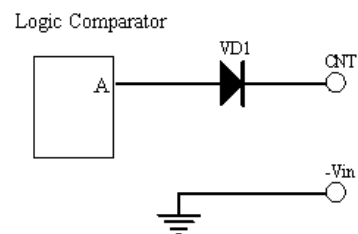

Internal circuit diagram for positive logic control

WLD30-48S12L DC-DC Converter

Input 18V~75V Output 12V/2.5A 1in.×2 in. Industry Standard Size

Output Voltage Adjust

The converters have an Output Voltage adjust pin (Trim). This pin can be used to adjust the output voltage above or below Output voltage initial setting. Output voltage adjust range is ±10 % of the rated output voltage, The output power can not exceed 30W at increased output voltages, and the output current can not exceed 2.5A, when the trim pins are not used, they should be floated.

External circuit is connected as the figure shown, the resistance is calculated as the formula below.

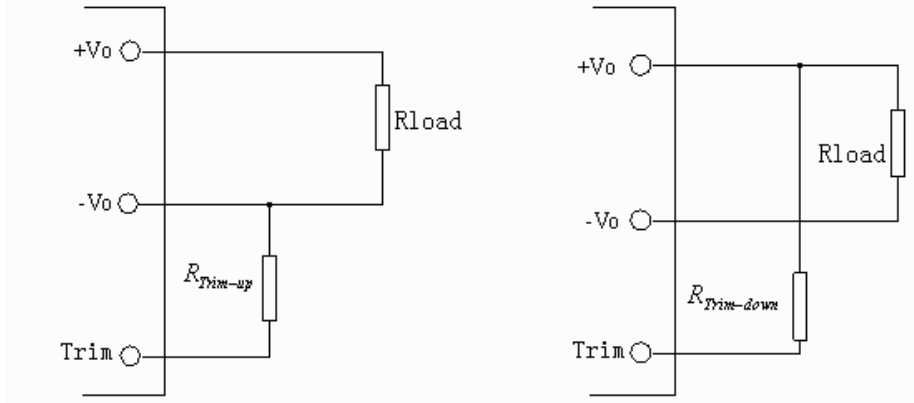

Connection of Trimming Up

Connection for Trimming Down

Resistance for trimming up : $R_{Trim-up} = \left(\frac{23.78}{\Delta V - 0.044} - 15 \right) (k\Omega)$

Resistance for trimming down: $R_{Trim-down} = \left(\frac{91.0}{\Delta V + 0.044} - 24.53 \right) (k\Omega)$

Vo: rated output voltage, 12V.

ΔV: The output voltage change.

$R_{Trim-up}$ 、 $R_{Trim-down}$: Resistance for trimming up or down, kΩ.

Thermal Consideration

The converters operate in a variety of thermal environments; however, sufficient cooling should be provided to ensure reliable operation of the unit. Heat is removed by conduction, convection and radiation to the surrounding environment.

When ambient temperature is higher than the permitted operating, the derating curves should be referred or external heat dissipation measures. Forced air cooling or heatsink, should be used. The air tunnel should be considered for forced air cooling, to avoid heated air be hindered or forming swirl; when heatsink used, it should be attached the converter closely, through double-side thermal conductivity insulation adhesive or thermal conductivity silicone for heat exchange.

Safety Consideration

To avoiding fire and be protected when short circuit occurred, it is recommended that a fast blow fuse with rating 2.5 to 3 times of converter’s continuous input peak current is used in series at the input terminal. (Inrush current suppression circuit is required for greater filter capacitance at input terminal, or it will result in the misoperation of the fuse).

EMC Consideration

EN55032 CLASSB recommendation circuit:

WLD30-48S12L DC-DC Converter

Input 18V~75V Output 12V/2.5A 1in.×2 in. Industry Standard Size

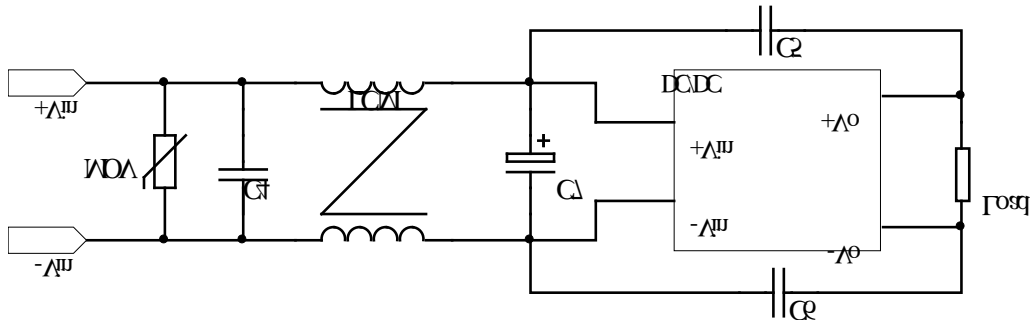

Parameter description:

Part No.	Components	Part No.	Components
MOV	101KD14	C5	2000V/1nF
LCM	> 13mH Common Mode Inductors	C6	2000V/1nF
C4	100V/1μF	C7	100V/220μF

Series and Parallel Operation

The converters should not be paralleled directly to increase power, but they can be paralleled each other through o-ring switches or diodes. Make sure that every converter's maximum load current should not exceed the rated current at anytime if they are paralleled without using external current sharing circuits.

The converters can operate in series. To prevent against start-up failure due to start up time difference, SBD with low voltage difference can be paralleled at the output pins(SBD negative terminal connect to the positive pin of the output) for each converter.

Cleaning Notice

The converter case is not a hermetically-sealed construction, a sufficient drying process is required after the converter cleaning, make sure the liquid congregated is removed, or it will damage the converter or degradation of performance. After surface treatment, the appearance of the converter may be affected by the organic solvent, protection measures should be taken before cleaning when appearance is concerned.

Delivery Package Information

Package material is multiple wall corrugated , internal material is anti-static foam, it's surface resistance is from $10^5 \Omega$ to $10^{12} \Omega$. Tray capacity: $2 \times 16 = 32$ PCS/box, Tray weight: 1.04kg; Carton capacity: $8 \times 32 = 256$ PCS, Carton weight: 9.0kg.

Quality Statement

The converters are manufactured in accordance with ISO 9001 system requirements, in compliant with YD/T1376-2005, and are monitored 100% by auto-testing system, 100% burn in.

The warranty for the converters is 5-year.

Contact Information

Anhui Hesion Trading Co.,Ltd.
& Beijing Yihongtai Technology Dev.Co.,Ltd

TEL: +86-551-65369069,65369067

Email: alecz@ahhesion.com

Backup:alecz@126.com

www.ahhesionpower.com