

YPD600-110S24 DC-DC Converter

Input 66V~160V, Output 24V/25A, Full Brick Series

Contents

Features.....	1
Outline Diagram	2
Specifications.....	3
Characteristic Curves.....	4
Design Considerations	6
Basic Connection	6
Recommended Layout	7
Input Voltage Range.....	7
Remote Control.....	7
Output Voltage Adjust.....	8
Remote Sense.....	9
Over Temperature Protection	9
Output Over Voltage Protection	9
Alarm Function	10
AUX Power supply	10
Safety Consideration.....	10
Series and Parallel Operation.....	11
Delivery Package Information	11
Quality Statement	11
Contact information	11



Features

- ◆ **Full Brick (116.8mm×61.0mm×13.2mm)**
- ◆ **Input Under Voltage Protection (55V to 65V Turn off)**
- ◆ **Negative Logic Control (Turn on Between -0.7V to 0.7V)**
- ◆ **Output Over Voltage Protection (28.8V to 33.6V)**
- ◆ **Output Voltage Adjust Range: ±10% of the rated output voltage**
- ◆ **Output Short-circuit Protection, hiccup, auto-recovery**
- ◆ **5% Output Current Sharing**
- ◆ **High Efficiency up to 90% (110V, full load)**
- ◆ **1500V_{ac} Isolation Voltage**
- ◆ **-40 °C to +100 °C Operating Baseplate Temperature**
- ◆ **115 °C typ. Over Temperature Protection**

- ◆ **Applications: Telecommunication electronic data processing, distributed power architecture and Railway & Rail transit.**

YPD600-110S24 DC-DC Converter

Input 66V~160V, Output 24V/25A, Full Brick Series

Outline Diagram

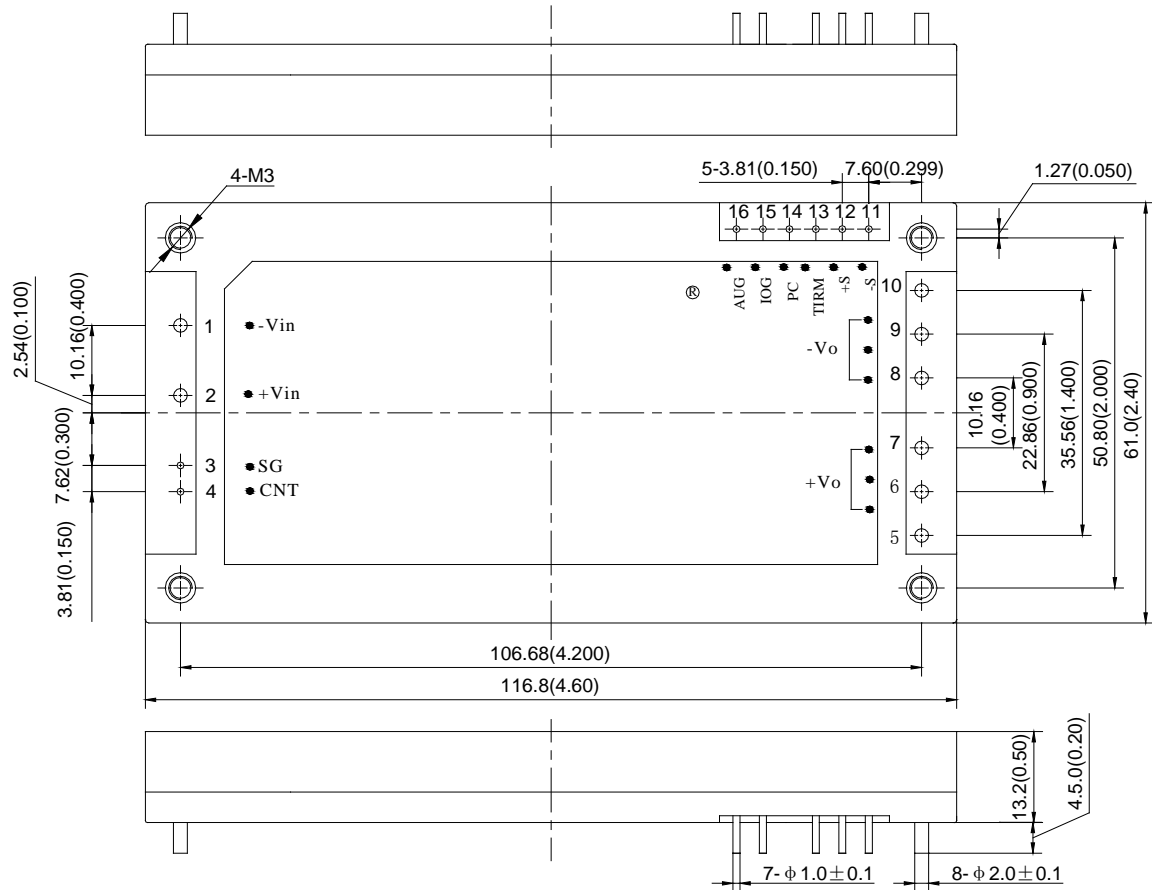

Case material: Black flame retardant Plastic; Pins: copper with tin-cerium plating
 Aluminum baseplate can be connected to Protective Earth pin by M3 screw.

Notes: all dimensions in mm(inch)

Tolerances: X. X±0.5mm(X.XX±0.02inch) X.XX±0.25mm(X.XXX±0.010inch)

Pin	Symbol	Function	Pin	Symbol	Function
1	-Vin	Negative Input	11	-S	Negative Remote Sense, connected to -V _O when not be used
2	+Vin	Positive Input	12	+S	Positive Remote Sense, connected to +V _O when not be used
3	SG	Remote ON/OFF Return	13	TRIM	Output adjustment trim pin
4	CNT	Remote control signal input, Input voltage range 4V-35V DC	14	PC	Current sharing pin, the pins are connected when converters are paralleled to increase output power
5,6,7	+Vo	24V Positive output	15	IOG	Operating condition indication, low level means normal, high level means abnormal
8,9,10	-Vo	24V Negative Output	16	AUX	Aux power supply, the max current 20mA can be sourced at the pin

YPD600-110S24 DC-DC Converter

Input 66V~160V, Output 24V/25A, Full Brick Series

Specifications

Unless otherwise specified, all values are given at room temperature and standard atmosphere pressure, pure resistive load and basic connection.

Input	Symbol	Min	Typ	Max	Unit	Conditions	
Input Voltage	V_{in}	66	110	160	V	—	
Input Current	I_{in}	—	—	10.57	A	$V_{in} = 66V$, full load	
Negative Logic Remote Control	ON	—	-0.7	—	0.7	V	Refer to SG
	Current	—	—	—	0.5	mA	CNT source current when turn on
	OFF	—	4	—	35	V	Refer to SG
	Current	—	—	—	1.0	mA	CNT sink current when turn off
Start-up Delay Time	T_{delay}	—	200	—	ms	$V_{in} = 110V$, $I_o = 25A$	
Under Voltage Threshold	V_{UVLO}	55	—	65	V	—	
Under Voltage Protection Hysteresis	ΔV_{UVLO}	1	—	3	V	—	

Output	Symbol	Min	Typ	Max	Unit	Conditions	
Output Power	P_o	0	—	600	W	—	
Output Voltage	V_o	23.76	24.00	24.24	V	—	
Output Current	$I_{O,nom}$	0	—	25	A	—	
Output Voltage Adjust Range	V_{trim}	21.6	—	26.4	V	$I_o \leq 25A$, $P_o \leq 600W$	
Line Regulation	S_V	—	—	± 0.2	% V_o	$V_{in}: 66V \sim 160V$, $I_o = 25A$	
Load Regulation	S_I	—	—	± 0.5	% V_o	$V_{in}: 110V$, $I_o = 0A \sim 25A$	
Output Overvoltage Protection Set Point	$V_{ov,set}$	28.8	—	33.6	V	Lockout, restart up after turn-off	
Output Overcurrent Protection Set Point	$I_{O,lim}$	27.5	—	40	A	—	
Output Short-circuit Protection	cycle by cycle protected, auto-recovery, recommended short circuit protection time < 5s						
Peak to Peak Ripple and Noise	ΔV_{pp}	—	—	240	mV	20MHz bandwidth	
Rise Time	T_{rise}	—	50	—	ms	$I_{o,nom}$, Pure resistive load	
Capacitive Load Range	C_o	0	—	4700	μF	—	
Current Sharing Accuracy	—	—	—	± 5	%	$I_o: 6A \sim 25A$	
Load Transient	Recovery Time	t_{tr}	—	—	400	μs	Loadchange: 25%-50%-25% & 50%-75%-50% Current change: 0.1A/ μs
	Voltage Deviation	ΔV_{tr}	—	—	± 960	mV	
AUX Power Supply	Voltage	V_{AUX}	11	—	14	V	—
	Current	I_{AUX}	0	—	20	mA	

YPD600-110S24 DC-DC Converter

Input 66V~160V, Output 24V/25A, Full Brick Series

General	Symbol	Min	Typ	Max	Unit	Conditions
Efficiency	η	88	90	—	%	$V_{in} = 110V, I_{o,nom}$
Switching Frequency	f_s	—	250	—	kHz	The ripple is 2 frequency
Isolation Resistance	R_{iso}	50	—	—	M Ω	—
Isolation Voltage	V_{iso}	1500	—	—	V_{ac}	Input to output, leakage current $\leq 10mA$
		1500	—	—	V_{ac}	Input to case, leakage current $\leq 10mA$
		500	—	—	V_{dc}	Output to case, leakage current $\leq 0.5mA$
Operating Baseplate Temperature	—	-40	—	100	$^{\circ}C$	—
Storage Temperature	—	-55	—	125	$^{\circ}C$	—
Temperature Coefficient	S_T	—	—	± 0.02	%/ $^{\circ}C$	—
OTP Set Point	T_{ref}	105	115	120	$^{\circ}C$	—
OTP Hysteresis	ΔT_{ref}	—	10	—	$^{\circ}C$	
MTBF	—	—	2×10^6	—	h	BELLCORE TR-332
Vibration	Sine, Frequency:10Hz to 55Hz, Amplitude:0.35mm, 30 min in each of 3 perpendicular directions					
Shock	Half sine, peak acceleration:300m/s ² , duration:6 ms; continuous 6 times of pulse in each of 3 perpendicular directions					
Hand Soldering	Maximum soldering Temperature < 425 $^{\circ}C$, and duration < 5s					
Wave Soldering	Maximum soldering Temperature < 255 $^{\circ}C$, and duration < 10s					
Weight	—	—	175	—	g	—

Characteristic Curves

Load Transient Response

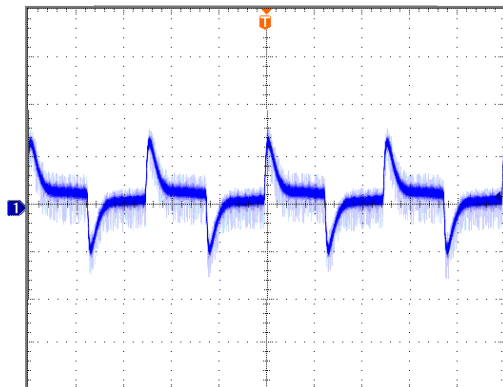

Load change: 25%~50%
 ~25% $I_{o,nom}$, 0.1A/ μs
 $V_{in} = 110Vdc$
 Trace1: 200mV/div
 Time scale: 0.4ms/div

Load Transient Response

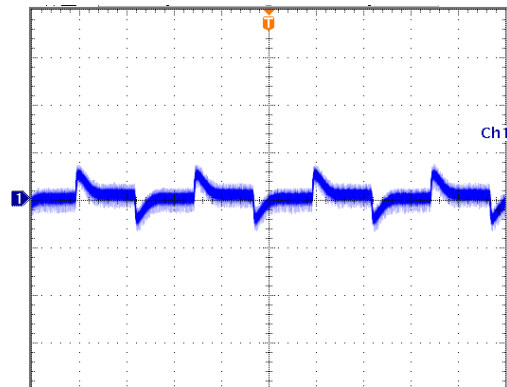

Load change: 50~75%
 ~50% $I_{o,nom}$, 0.1A/ μs
 $V_{in} = 110Vdc$
 Trace1: 500mV/div
 Time scale: 0.4ms/div

YPD600-110S24 DC-DC Converter

Input 66V~160V, Output 24V/25A, Full Brick Series

Output Ripple and noise

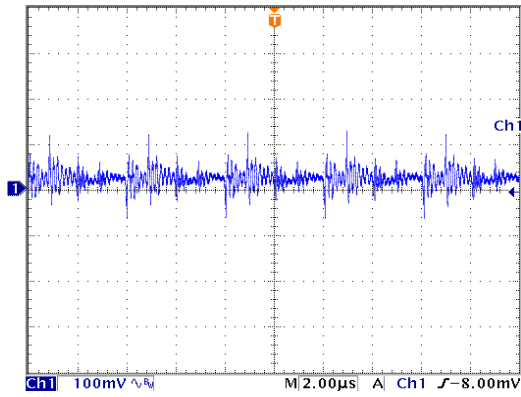

$V_{in} = 110V_{dc}$, $I_o = 25A$

Start-up Delay Time

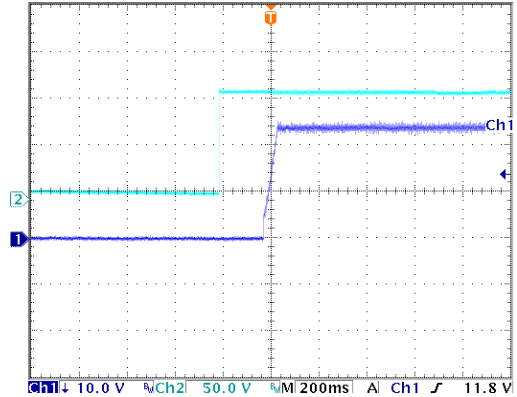

$V_{in} = 110V_{dc}$, $I_o = 25A$

Rise Time

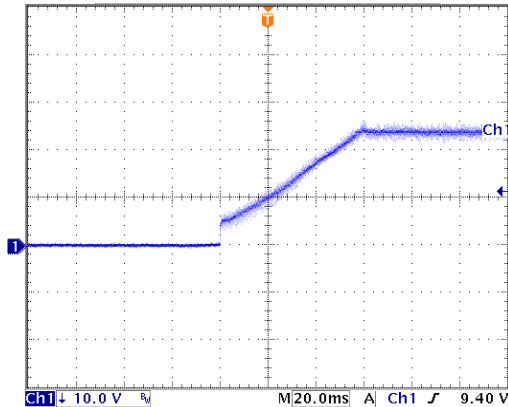

$V_{in} = 110V_{dc}$, $I_o = 25A$

Turn-off

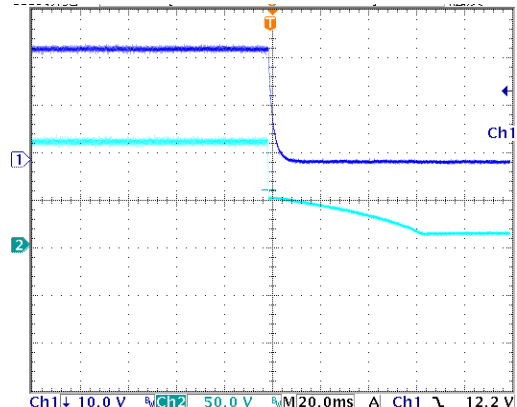

$V_{in} = 110V_{dc}$, $I_o = 25A$

Natural cooling derating curve

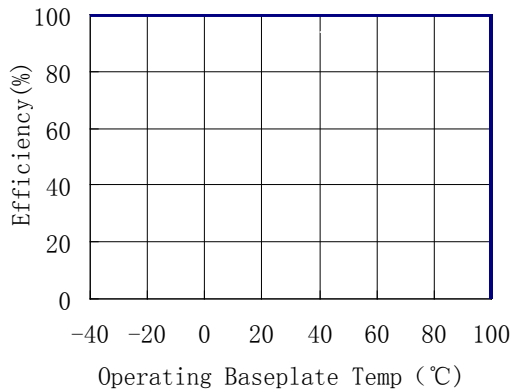

Typical efficiency curve

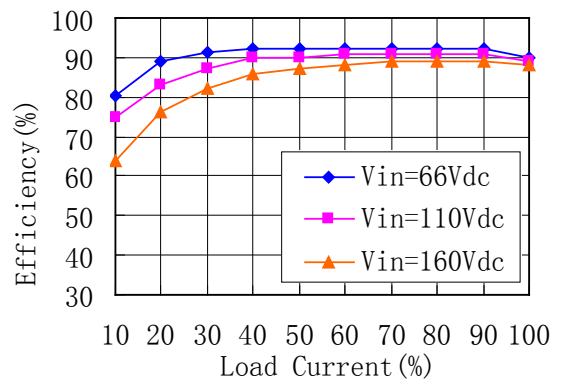

YPD600-110S24 DC-DC Converter

Input 66V~160V, Output 24V/25A, Full Brick Series

Design Considerations

Basic Connection

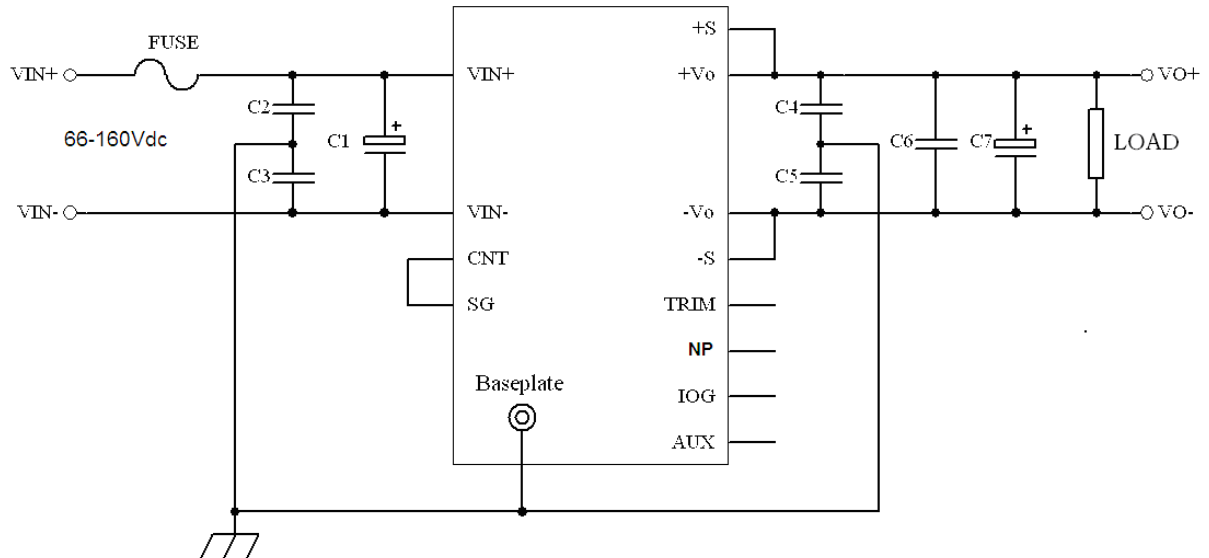

The recommended parameters in the circuit are as follows:

FUSE: 25A, fast recovery.

C1: 100uF electrolytic capacitor with low ESR, when ambient temperature below -20°C or input lines have greater inductance, two or more 100uF electrolytic capacitors should be paralleled.

C2, C3: 1000pF high-voltage ceramic capacitors, withstand voltage $> 3\text{kVac}$, the wire connected to the case should be as short as possible.

C4, C5: 22nF high-voltage ceramic capacitors, withstand voltage $> 500\text{Vdc}$, the wire connected to the case should be as short as possible.

C6: 22uF ceramic capacitor.

C7: 2200uF electrolytic capacitor, when ambient temperature below -20°C , two or more capacitors with 2200uF should be paralleled.

Notes: When trimming up/down are not in use, +S and +Vo should be connected directly, -S and -Vo should be connected directly as well, otherwise over voltage protection will be triggered after voltage applied. The basic connection indicates the basic requirements. Please refer to the instruction followed for further information.

YPD600-110S24 DC-DC Converter

Input 66V~160V, Output 24V/25A, Full Brick Series

Recommended Layout

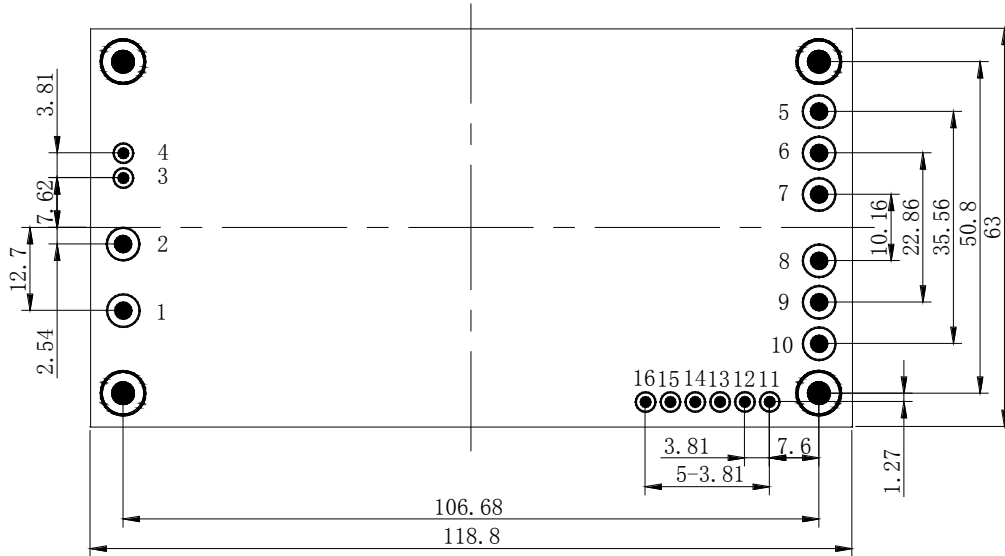

NO.	Recommendation & Notes
Pad Design	3, 4, 11-16 Pad holes: 1.5mm, pad diameter including hole:2.5mm; Pad hole 1, 2, 5-10 are 2.5mm, pad diameter including hole:4mm; the fixed holes at the four corners are metallized, with diameter of 3.3mm and pad diameter including hole: 5mm.
Airflow Direction	The air should flow along the direction of the heat sink.
Safety	Isolated Converters, care to the spacing between input and output, input and protective ground output and protective ground.
Electrical	The Vin(-) and Vo(-) planes should be placed under of the converter separately. Avoid routing sensitive signal or high disturbance AC signal under the converter.

Input Voltage Range

The input voltage range of the DC/DC converter is 66V~160V. The input impedance of the converter looks like a negative resistor, which can interact with the reactance of the power bus (including any filter elements that have been added to the input of the converter), causes an unstable condition. Depending on the internal transformer’s impedance, the external impedance usually should not exceed the 10% of the internal. The source impedance of the Power bus should be kept as low as possible. Less than 6 ohm is recommended.

Wherever the input voltage of the converter comes from, AC mains or switching modules, the peak to peak of the voltage ripple should not be more than 20V. Otherwise the output voltage ripple will increase, unless protection circuit is equipped.

Remote Control

Remote control can be offered by setting right control voltage level (refer to SG pin, floating, high resistance) to CNT pin. When the level is higher than 4.0V or be left floating, the converter will turn off. When the level is less than 0.7V, the converter will turn on.

YPD600-110S24 DC-DC Converter

Input 66V~160V, Output 24V/25A, Full Brick Series

YPD600-110S24 is provided with negative logic remote control. The circuit diagram is shown as “internal circuit diagram for negative logic control”, when low level applied, the CNT source current is less than 1mA, due to VD1 is signal diode, and the logic comparator is semiconductor integrated chip with low resistance to surge. Care should be taken to prevent CNT from surge, like application of TVS. When the pin floating, the voltage is 9V to 11V, the VCC is supplied from internal power supply.

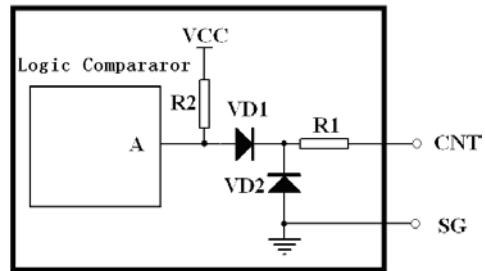

Internal circuit diagram for negative logic control

In some applications, extra controls will be designed

for the converter in user’s PCB, such as output short circuit protection, over voltage protection, under voltage protection, synchronous control to the converter output voltage, and so on, remote control will give you help. The controls can be achieved by external circuit applied to the CNT pin.

When the signal from the system is beyond 4V to 35V, or it can be enabled only within a very narrow control level (Requested to turn-off between 5.0V and 5.5V), the aux circuit will be required. Please contact Yihongtai for more information.

Output Voltage Adjust

The converters have an Output Voltage adjust pin (Trim). This pin can be used to adjust the output voltage above or below Output voltage initial setting.

The maximum value of the trimmed up is 10%, but it can not be gained within the whole input range, the maximum value of the trimmed up depends on the input voltage, the relationship between them are shown in figure: the relationship between output voltage trimmed up and input voltage. Even +S and –S pins are used to compensate the voltage simultaneously, the sum of the trimmed up and the compensation should not be more than 10%, or the characteristics will not be assured in compliant with the specification, even the over voltage protection may be triggered. The output power can not exceed 600W at increased output voltages. The maximum of the trimmed down is 10%, and the output current can not exceed 25A.

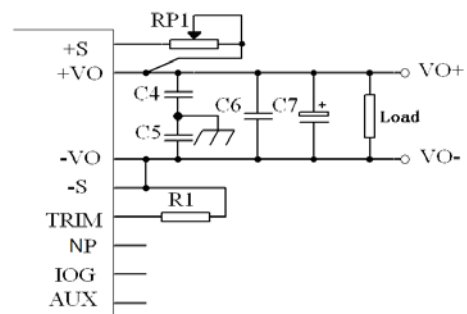

Output Voltage Adjust Connection of External Resistor

Output voltage could be adjusted by external resistor, shown as figure “Output Voltage Adjust Connection of External Resistor”, R1 is trimming down resistor, +S and +Vo should be connected when trimming down used only; RP1 is potentiometer for trimming up, R1 should be disconnected when trimming up used only. Implement of trimming up and trimming down simultaneously are not recommended, due to it will cause the converter unstable. If they are required to do so, please refer to “the R1 and RP1 Recommended for Trimming Up And Trimming Down Simultaneously”, R1 is invariable resistor with accuracy of less than $\pm 5\%$, and RP1 is variable resistor with accuracy of less than $\pm 20\%$. When resistance of RP1 is 0Ω , output voltage is minimum of trimmed down. Output voltage will increase to the maximum of the trimmed up with the resistance of RP1 increasing. Be noticed that

YPD600-110S24 DC-DC Converter

Input 66V~160V, Output 24V/25A, Full Brick Series

the voltage can not exceed the output voltage adjust range when trimming up, or the over voltage protection will be triggered, and the output will turn off when the circuit locked, RP1 can be replaced with invariable resistor after trimmed.

Output voltage could be adjusted by applying external voltage to Trim pin, shown as figure “Output Voltage Adjust Connection of applying external voltage at Trim”, output voltage can be determined by the formula shown below, $I_o = V_{nom} \times V_{Trim}$

Output voltage trimmed: V_o ; Voltage trimmed: V_{Trim} ; Rated voltage V_{nom} ; when adjusted the voltage by Trim pin, V_{Trim} range is 0.6V to 1.2V, it will cause converter abnormal operation when beyond the range.

Remote Sense

The remote sense can be used to compensate for the voltage drop between the output pins of the converter and the load input pins by +S and -S pins. The +S and -S pins should be connected to the input pins of the load respectively. The remote sense circuit will compensate for up to 10% voltage drop between the sense voltage and the voltage at the output pins.

The anti-interference design should be considered when the +S and -S pins are connected to the pins to be compensated. The +S and -S traces should be located close to a ground trace or ground plane, and the area they surrounded should be minimized (just for electrical isolation); If cable connection presents, twisted pair wires should be used, EMI core are equipped with the twisted pair wires to reduce common mode noise when necessary, the sense leads should not be longer than 200mm, or the system characteristics may not be assured.

The sense leads only can carry very little current, and are not used for converter power output. Care should be taken in operation to avoid damaging the converter.

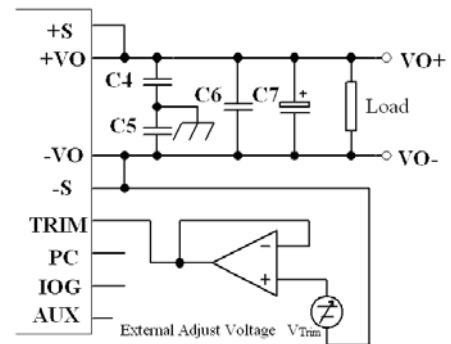

Output Voltage Adjust Connection of applying external voltage at Trim

Over Temperature Protection

The over temperature protection feature is used to protect the converter, and the sensor locates in the baseplate. If the temperature of the baseplate exceeds the threshold of 110°C, the converter will shut down, disabling the output. Until input voltage applied or restart up after remote off, the output will not resume. Please make sure the input voltage is below 10V before input voltage applied, the time between remote off and on is more than 100mS.

Output Over Voltage Protection

The switching-off type over voltage protection feature is used to protect the converter, when output voltage exceeds 120% to140% of the rated output voltage (the set point is between 120% to140%, there is the difference based on the specific parameters, but not beyond the range), the output voltage will shut down. Until input voltage applied or restart up after remote off, the output will not resume. Please make sure the input voltage is below 10V before input voltage applied, the time between remote off and on is more than 100mS.

YPD600-110S24 DC-DC Converter
 Input 66V~160V, Output 24V/25A, Full Brick Series

Alarm Function

Normal or abnormal operation of the converter can be monitored by using the IOG terminal. Compared to -S, the signal is LOW resistance when converter operates normally, and the signal is HIGH resistance when converter stops or operates abnormally.

Recommend circuit refers to “Circuit Connection of Operation Conditions Monitor”. External resistor R1 will applied when IOG signal used to monitor. After connection of external circuit, the converter operates under normal conditions, and IOG signal is low level and less than 0.3V; when converter faults or stops operating (except power off), IOG signal is high level V_{AUX} . The IOG becomes unstable for following conditions: over current protection, light load conditions at parallel operation, dynamic load operation. The maximum sink current of the IOG is 5mA, and the maximum applied voltage is 35V.

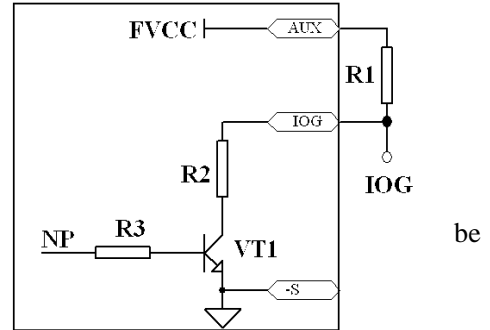

Circuit Connection of Operation Conditions Monitor

AUX Power supply

The AUX pin offers 11V to14V output voltage and maximum 20mA output current for AUX power supply. Ground for the AUX pin is -S pin. Avoid short circuit of AUX pin with other pins as this would lead to the converter damage in operation.

Safety Consideration

The converter, as one component for the end user, should be installed into the equipment, and all the safety considerations are achieved under certain condition. It is required to meet safety requirements in system design for the user.

To avoid fire and be protected when short circuit occurred, it is recommended that a fast blow fuse with rating 2.5 to 3 times of converter continuous input peak current is used in series at the input terminal. (Inrush current suppression circuit is required for greater filter capacitance at input terminal, or it will result in the misoperation of the fuse).

Series and Parallel Operation

The converters can be connected to increase power in parallel. Besides input pins and output pins are connected in parallel, the PC pins should be connected. Recommended connection is shown in the figure. When connected for current sharing, be sure that output voltage accuracy of each converter in parallel operation is within $\pm 1\%$, output power of each converter can not exceed the rated output power, and the total output power shall be less than 90% of the sum of every converter’s rated output power.

YPD600-110S24 DC-DC Converter

Input 66V~160V, Output 24V/25A, Full Brick Series

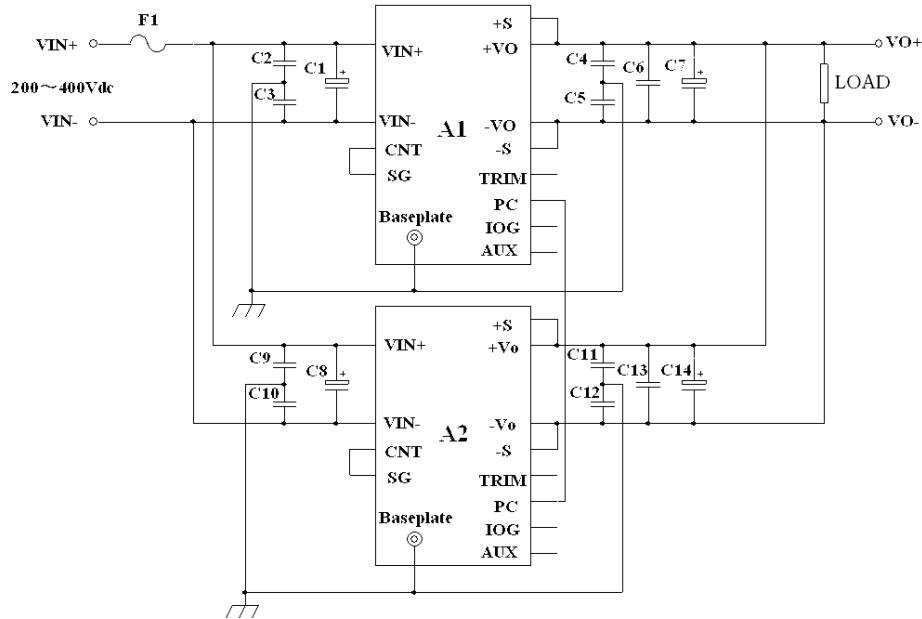

The Recommended Parallel Current Sharing Schematic

The converters can operate in series. To prevent against start-up failure due to time difference, SBD with low voltage difference can be paralleled at the output pins(SBD negative connect to the positive pin of the output) for each converter.

Delivery Package Information

Package material is multiple wall corrugated, internal material is anti-static foam, it's surface resistance is from $10^5 \Omega$ to $10^{12} \Omega$. Tray capacity: 6PCS/box, tray weight: 1.12kg; Carton capacity: $6 \times 8 = 48$ PCS, carton weight: 9.5kg.

Quality Statement

The converters are manufactured in accordance with ISO-9001 system requirements, in compliant with YD/T1376-2005, and are monitored 100% by auto-testing system, 100% burn in.

The warranty for the converters is 5-year.

Contact Information

Anhui Hesion Trading Co.,Ltd.
& Beijing Yihongtai Technology Dev.Co.,Ltd

TEL: +86-551-65369069,65369067

Email: alecz@ahhesion.com

Backup:alecz@126.com

www.ahhesionpower.com