

NTB1220DPD 20A Digital Non-isolated DC-DC Converters

Input 4.5V~14V, Output 0.6V~3.3V/20A, Dual-in-line Package

Features

- ◆ Package 25.7mm×13.8mm×8.2mm
- ◆ PMBus with the functions of monitor and configuration
- ◆ Remote On/Off (turn on when left floating)
- ◆ High Efficiency, 94% typ. (input:12V,output:3.3V)
- ◆ Synchronizes external clock/Current-sharing
- ◆ Input Under-voltage Protection
Input Over-voltage Protection
- ◆ Output voltage boundary limit
- ◆ Operating Temperature: -40 °C to +85 °C
- ◆ Output Short-circuit Protection
- ◆ Output Current Limit Protection
- ◆ Output Over-temperature Protection
- ◆ Application: Telecommunication equipments, data exchange servers and distributed power architectures etc.



Digital Interface through the PMBus protocol

Contents

Features	1
Contents	1
Outline Diagram	2
Specifications	2
Characteristic Curves (Vo=0.6V)	6
Characteristic Curves (Vo=1.0V)	7
Characteristic Curves (Vo=1.8V)	8
Characteristic Curves (Vo=3.3V)	9
Design Considerations.....	10
Basic Connection.....	10
Recommended Layout.....	10
The Ripple Test.....	11
Input Voltage Range	11
Input Under Voltage Protection	11
Remote Control	11
External Capacitance	11
Optimization of the Transient Load Response.....	11
Output Voltage Adjust.....	12
Output Over Voltage Protection.....	12
The Switching Frequency	12
The Current Sharing	13
Output Over Current Protection	13
Over Temperature Protection.....	13
The PMBus Interface.....	13
The PMBus Monitoring Function.....	13
The PMBus Address	13
The PMBus Commands.....	14
The Software Tools.....	16
Thermal Consideration	16
Delivery Package Information.....	16
Quality Statement	16
Contact Information.....	17

NTB1220DPD 20A Digital Non-isolated DC-DC Converters

Input 4.5V~14V, Output 0.6V~3.3V/20A, Dual-in-line Package

Outline Diagram

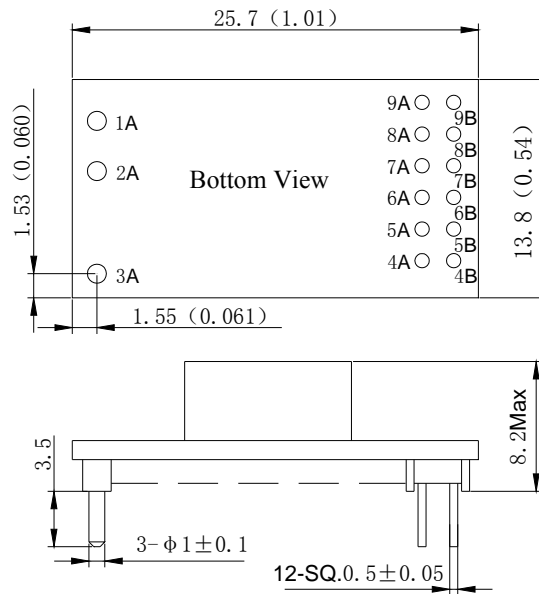

PCB Material: Multilayer PCB **Pins:** Copper with gold plating

Notes: All dimensions in mm(inches) **Tolerances:** X.X ± 0.5 (X.XX ± 0.02) X.XX ± 0.25 (X.XXX ± 0.010)

Pins	Symbol	Function
1A	Vo	Positive output pin , with the GND pin constitute the output circuit.
2A	GND	Common ground for input and output.
3A	Vin	Positive input pin, with the GND pin constitute an input circuit.
4A	SALERT	PMBus serial alarm output pin.
4B	CTRL	Remote control pin.
5A	VSET	Output voltage regulating pin, voltage be trimmed up or down by applying external resistance or level connected to the pin.
5B	SYNC	Synchronize clock pin.
6A	SCL	PMBus communication clock line.
6B	SDA	PMBus communication address line.
7A	SA0	PMBus address pin,and which be used to set different addresses when multiple modules are parallel used.
7B	GCB	Data communication bus.
8A	+S	Positive remote sense pin.
8B	-S	Negative remote sense pin.
9A	VTRK	External input voltage source tracking pin.
9B	PREF	Communication pin.

Specifications

Unless otherwise specified, all tests are at room temperature and standard atmosphere, pure resistive load. When testing, a 470μF/10mΩ capacitor is required to connected to the input and output pins separately.

Input	Symbol	Min	Typ	Max	Unit	Conditions
Input Voltage	V _{in}	4.5	12.0	14.0	V	—
Input Current	I _{in}	—	—	15	A	—
Remote Control Loss	—	—	—	180	mW	—

NTB1220DPD 20A Digital Non-isolated DC-DC Converters
Input 4.5V~14V, Output 0.6V~3.3V/20A, Dual-in-line Package

Continue

Input		Symbol	Min	Typ	Max	Unit	Conditions
Positive Logic Control	On	–	2	–	–	V	refer to PREF; Turn on when CTRL floating
	Off	–	–	–	0.8	V	refer to PREF
	Current	–	–	–	0.6	mA	CTRL source current when turn off
Input Under Voltage Protection	Protection Point	V_{UVLO}	–	3.85	–	V	$V_O \leq 3.3V$, factory settings
	Protection Range	V_{UVLO}	3.85	–	14	V	PMBus configurable
	Setting Precision	–	-150	–	150	mV	–
	Hysteresis	ΔV_{UVLO}	–	0.35	–	V	factory settings
	Hysteresis Range	ΔV_{UVLO}	0	–	10.15	V	PMBus configurable
	Response Time	–	–	25	–	μs	factory settings
	Response Time Range	–	5	–	60	μs	PMBus configurable
	Error Response Time	–	–	70	–	ms	PMBus configurable
Input Over Voltage Protection	Protection Point	V_{OVLO}	–	16	–	V	$V_O \leq 3.3V$, factory settings
	Protection Range	V_{OVLO}	4.2	–	16	V	PMBus configurable
	Setting Precision	–	-150	–	150	mV	PMBus configurable
	Hysteresis	ΔV_{OVLO}	–	1	–	V	–
	Hysteresis Range	ΔV_{OVLO}	0	–	11.8	V	PMBus configurable
	Response Time	–	–	25	–	μs	factory settings
	Response Time Range	–	5	–	60	μs	PMBus configurable
	Error Response Time	–	–	70	–	ms	PMBus configurable

Output	Symbol	Min	Typ	Max	Unit	Conditions
Output Voltage	V_O	–	1.2	–	V	factory settings
		0.6	–	3.3	V	–
Output Current	I_O	0	–	20	A	–
Line Regulation	S_V	–	2	4	mV	$V_O=0.6V$
		–	2	4	mV	$V_O=1.0V$
		–	2	4	mV	$V_O=1.8V$
		–	3	6	mV	$V_O=3.3V$

NTB1220DPD 20A Digital Non-isolated DC-DC Converters
Input 4.5V~14V, Output 0.6V~3.3V/20A, Dual-in-line Package

Continue

Output		Symbol	Min	Typ	Max	Unit	Conditions
Load Regulation		S_I	-	3	6	mV	$V_{in}=12V, V_O=0.6V$
			-	2	9	mV	$V_{in}=12V, V_O=1.0V$
			-	2	9	mV	$V_{in}=12V, V_O=1.8V$
			-	2	10	mV	$V_{in}=12V, V_O=3.3V$
Output Over Voltage Protection Point	$V_{ov,set}$	-	115	-	% V_O	factory settings	
Output Over Voltage Protection Point Range	$V_{ov,set}$	100	-	115	% V_O	PMBus configurable	
Output Over Voltage Error Response Time	-	-	70	-	ms	PMBus configurable	
Output Over Current Protection Range	$I_{O,lim}$	-	26	-	A	factory settings	
		0	-	28	A	PMBus configurable	
Output Over Current Setting Precision	-	-	-	± 2.6	A	—	
Output Over Current Response Time	-	-	5	-	Tsw	factory settings	
	-	1	-	32	Tsw	PMBus configurable	
Output Over Current Error Response Time	-	-	70	-	ms	PMBus configurable	
Peak to Peak Ripple and Noise	ΔV_{pp}	-	-	60	mV	See “The Ripple Test”	
Rise Time	T_{rise}	-	10	-	ms	factory settings $I_{O,max}$, pure resistive load	
Rise Time Setting Range	T_{rise}	5	-	200	ms	PMBus configurable $I_{O,max}$, pure resistive load	
Rise Time Setting Precision	-	-	± 1	-	ms	PMBus configurable	
Start-up Delay Time	T_{delay}	-	50	-	ms	factory settings $I_{O,max}$, pure resistive load	
Start-up Delay Time Range	T_{delay}	50	-	30050	ms	PMBus configurable $I_{O,max}$, pure resistive load	
Start-up Delay Time Setting Precision	-	-1	-	+5	ms	PMBus configurable	
Output Short-circuit Protection	automatic recovery						
Current Share Precision	-	-	20	-	%	$I_{O,max}$	
Output Overshoot	V_{TO}	0	-	10	% V_O	$V_{in}: 4.5V-14.0V, I_{O,max}$	
Capacitive Load	C_O	470	-	10000	μF	—	
Load Transient	Recovery Time	t_{tr}	-	-	80	μs	$V_{in}=12V, V_O=0.6V$ 25%~50%~25% $I_{O,nom}$; 0.1A/ μs
	Voltage Deviation	ΔV_{tr}	-	-	± 95	mV	
	Recovery Time	t_{tr}	-	-	90	μs	$V_{in}=12V, V_O=1.0V$ 25%~50%~25% $I_{O,nom}$; 0.1A/ μs
	Voltage Deviation	ΔV_{tr}	-	-	± 95	mV	

NTB1220DPD 20A Digital Non-isolated DC-DC Converters
Input 4.5V~14V, Output 0.6V~3.3V/20A, Dual-in-line Package

Continue

Output		Symbol	Min	Typ	Max	Unit	Conditions
Load Transient	Recovery Time	t_{tr}	-	-	100	μs	$V_{in}=12\text{V}, V_O=1.8\text{V}$ 25%~50%~25% $I_{O,nom}; 0.1\text{A}/\mu\text{s}$
	Voltage Deviation	ΔV_{tr}	-	-	± 100	mV	
	Recovery Time	t_{tr}	-	-	100	μs	$V_{in}=12\text{V}, V_O=3.3\text{V}$ 25%~50%~25% $I_{O,nom}; 0.1\text{A}/\mu\text{s}$
	Voltage Deviation	ΔV_{tr}	-	-	± 180	mV	

General	Symbol	Min	Typ	Max	Unit	Conditions
Efficiency	η	-	78	-	%	$V_{in}=12.0\text{V}, 20\text{A}, V_O=0.6\text{V}$
		-	85	-	%	$V_{in}=12.0\text{V}, 20\text{A}, V_O=1.0\text{V}$
		-	91	-	%	$V_{in}=12.0\text{V}, 20\text{A}, V_O=1.8\text{V}$
		-	94	-	%	$V_{in}=12.0\text{V}, 20\text{A}, V_O=3.3\text{V}$
Switching Frequency	f_s	220	-	640	kHz	PMBus configurable
MTBF	-	-	5×10^6	-	h	BELLCORE TR-332
Operating Temperature	-	-40	-	+85	$^{\circ}\text{C}$	meet derating curve
Storage Temperature	-	-55	-	+125	$^{\circ}\text{C}$	—
Relative Humidity	-	10	-	90	%	non condensing, $40^{\circ}\text{C} \pm 2^{\circ}\text{C}$
Temperature Coefficient	S_T	-	-	± 0.02	$\%/^{\circ}\text{C}$	—
Over Temperature Protection Setting Point	T_{ref}	-	105	-	$^{\circ}\text{C}$	factory settings
Over Temperature Protection Setting Range	T_{ref}	-40	-	120	$^{\circ}\text{C}$	PMBus configurable
Over Temperature Protection Hysteresis	ΔT_{ref}	-	15	-	$^{\circ}\text{C}$	factory settings
Over Temperature Protection Hysteresis Setting Range	ΔT_{ref}	0	-	160	$^{\circ}\text{C}$	PMBus configurable
Over Temperature Protection Setting Precision	-	-10	-	10	$^{\circ}\text{C}$	—
Over Temperature Protection Response Time	-	-	70	-	ms	PMBus configurable
Vibration	Sine, Frequency:10Hz to 55Hz, Amplitude:0.35mm, 30 min in each of 3 perpendicular directions					
Shock	Half sine, peak acceleration:300m/s ² , duration:6 ms; continuous 6 times of pulse in each of 3 perpendicular directions					
Hand Soldering	Maximum soldering Temperature < 425 $^{\circ}\text{C}$, and duration < 5s					
Wave Soldering	Maximum soldering Temperature < 255 $^{\circ}\text{C}$, and duration < 10s					
Weight	-	-	5.7	-	g	—

NTB1220DPD 20A Digital Non-isolated DC-DC Converters

Input 4.5V~14V, Output 0.6V~3.3V/20A, Dual-in-line Package

Characteristic Curves (Vo=0.6V)

Load Transient Response

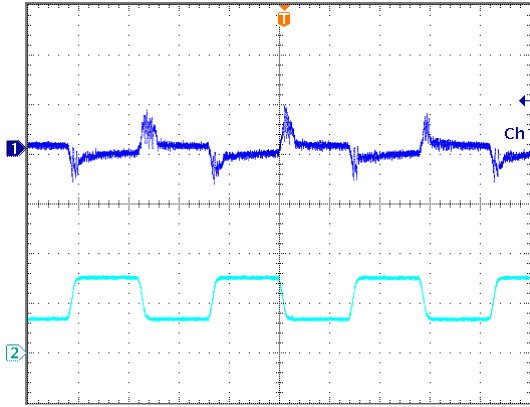

Load change: 25%~50%
 ~25% $I_{O,nom}$, 0.1A/ μ s
 V_{in} =12.0Vdc
 Trace1: 0.05V/div
 Trace2: 6A/div
 Time scale: 0.4ms/div

Output Ripple

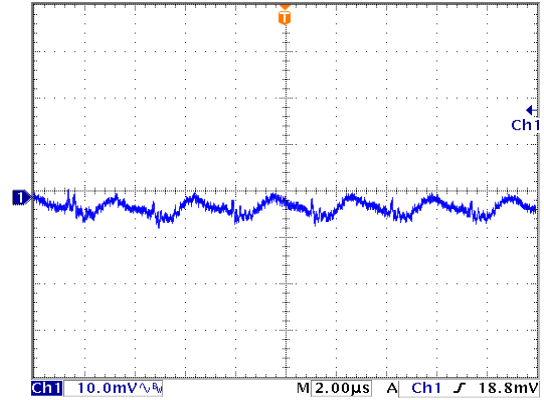

V_{in} =12.0Vdc

Start-up Delay Time

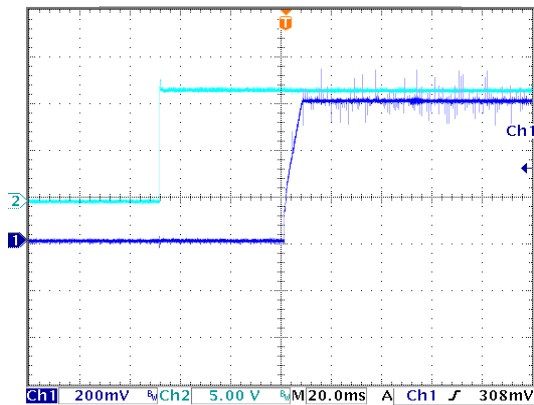

Turn-off

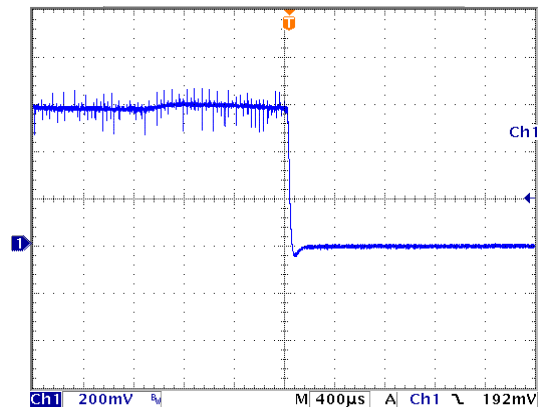

Efficiency vs Temperature and Current

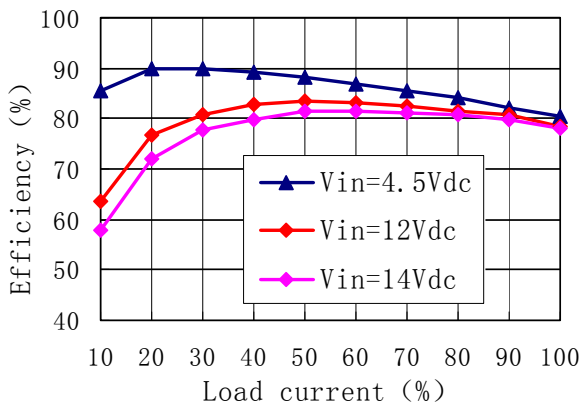

Derating (Vin=12.0Vdc)

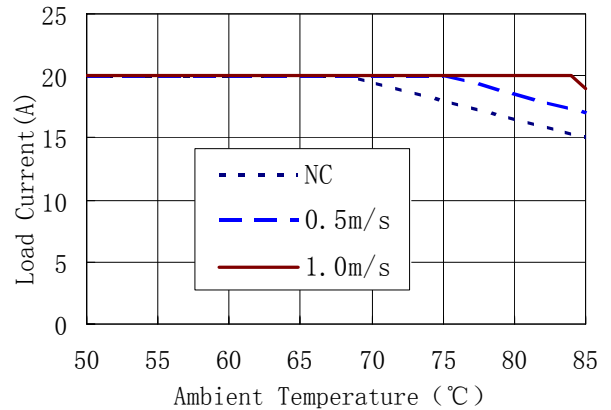

NTB1220DPD 20A Digital Non-isolated DC-DC Converters

Input 4.5V~14V, Output 0.6V~3.3V/20A, Dual-in-line Package

Characteristic Curves (Vo=1.0V)

Load Transient Response

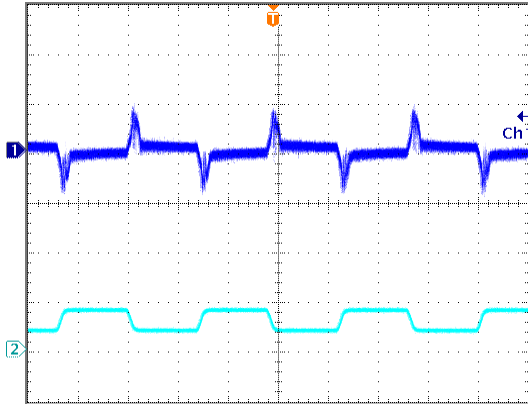

Load change: 25%~50% Trace1: 0.05V/div
 ~25% I_{O,nom}, 0.1A/μs Trace2: 6A/div
 V_{in}=12.0Vdc Time scale: 0.4ms/div

Output Ripple

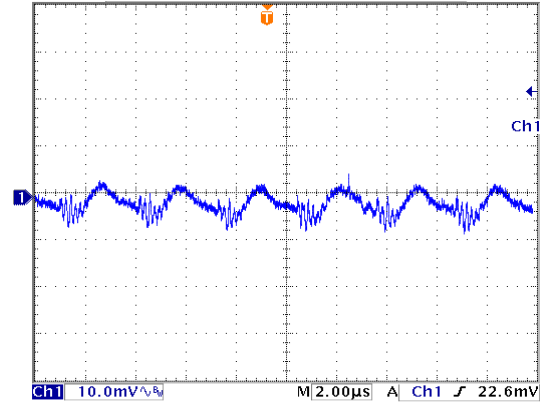

V_{in}=12.0Vdc

Start-up Delay Time

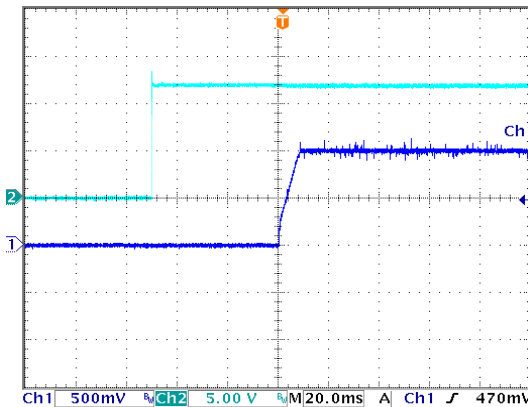

Turn-off

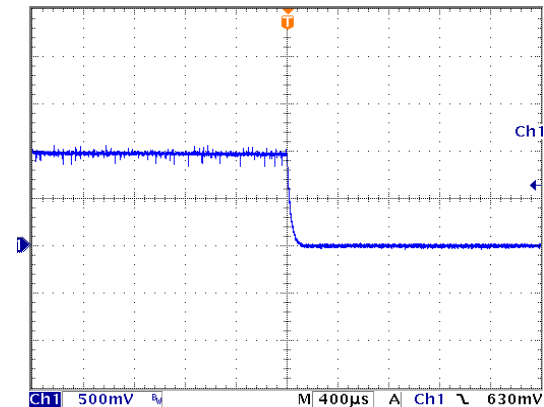

Efficiency vs Temperature and Current

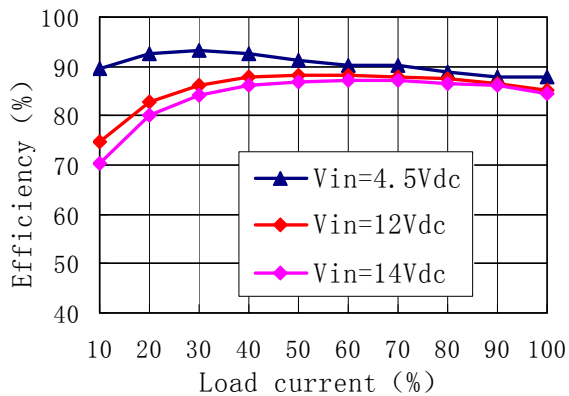

Derating(Vin=12.0Vdc)

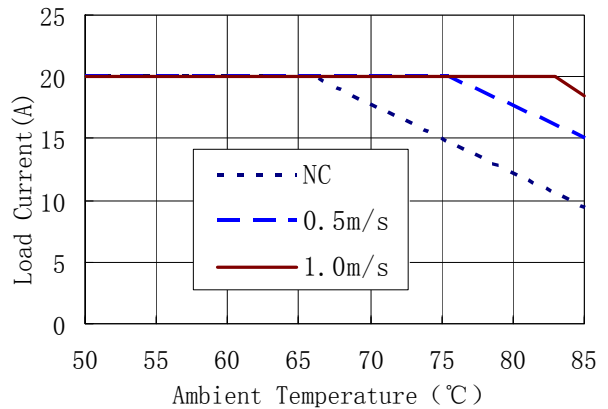

NTB1220DPD 20A Digital Non-isolated DC-DC Converters

Input 4.5V~14V, Output 0.6V~3.3V/20A, Dual-in-line Package

Characteristic Curves (Vo=1.8V)

Load Transient Response

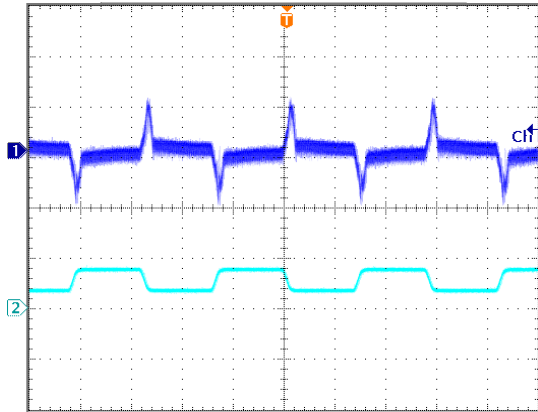

Load change: 25%~50%
 ~25% $I_{O,nom}$, 0.1A/ μ s
 $V_{in}=12.0Vdc$

Trace1: 0.05V/div
 Trace2: 6A/div
 Time scale: 0.4ms/div

Output Ripple

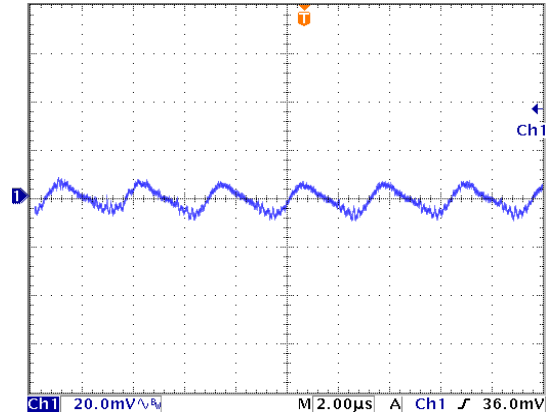

$V_{in}=12.0Vdc$

Start-up Delay Time

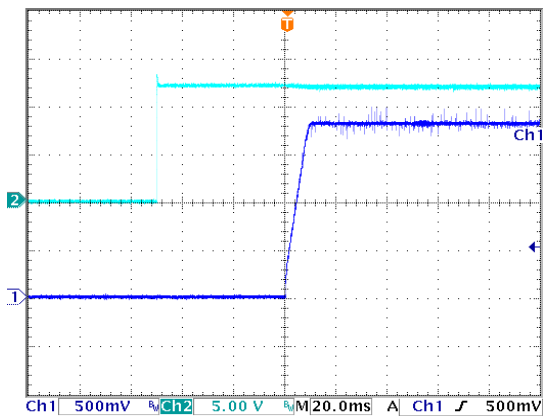

Turn-off

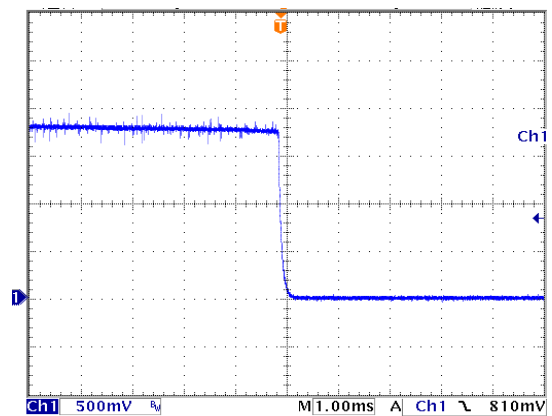

Efficiency vs Temperature and Current

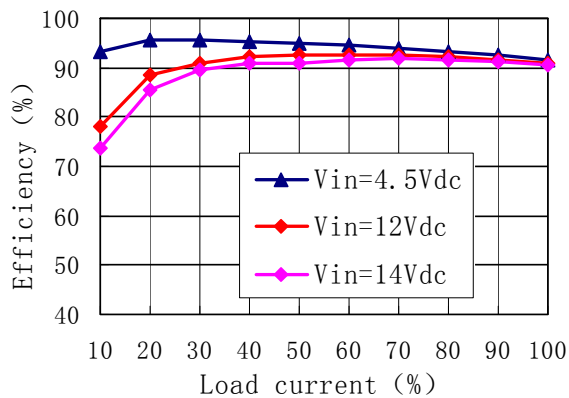

Derating(Vin=12.0Vdc)

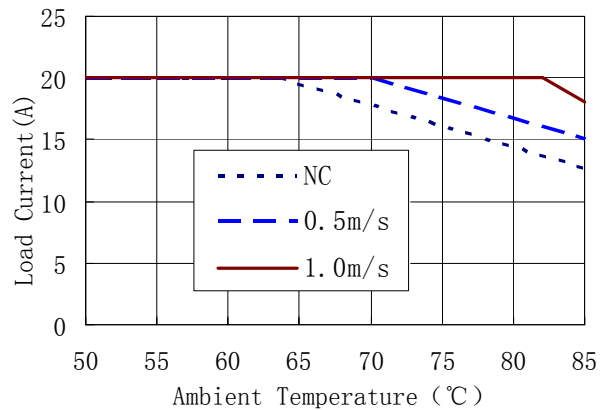

NTB1220DPD 20A Digital Non-isolated DC-DC Converters

Input 4.5V~14V, Output 0.6V~3.3V/20A, Dual-in-line Package

Characteristic Curves (Vo=3.3V)

Load Transient Response

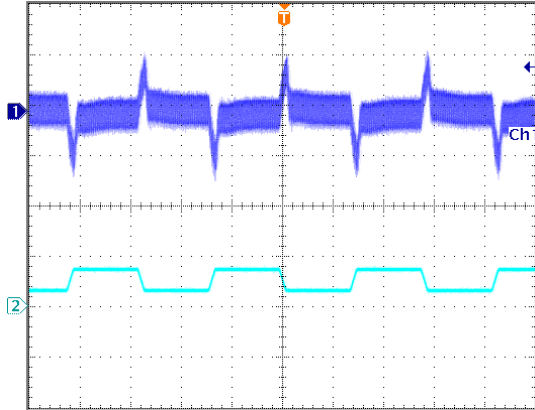

Load change: 25%~50% Trace1: 0.05V/div
 ~25% I_{O,nom}, 0.1A/μs Trace2: 6A/div
 Vin=12.0Vdc Time scale: 0.4ms/div

Output Ripple

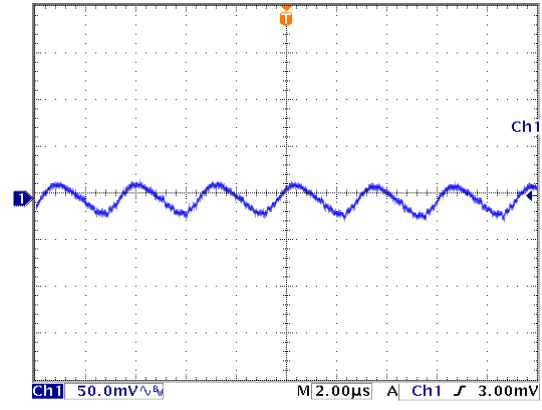

V_{in}=12.0Vdc

Start-up Delay Time

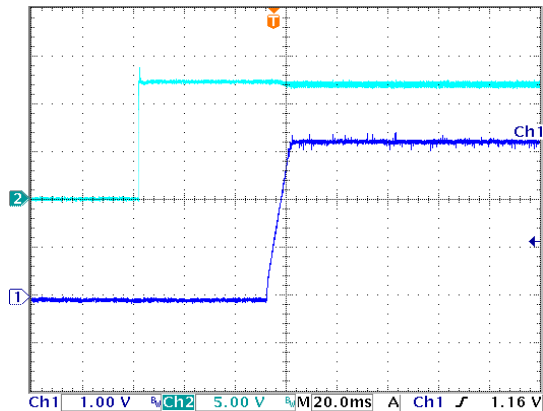

Turn-off

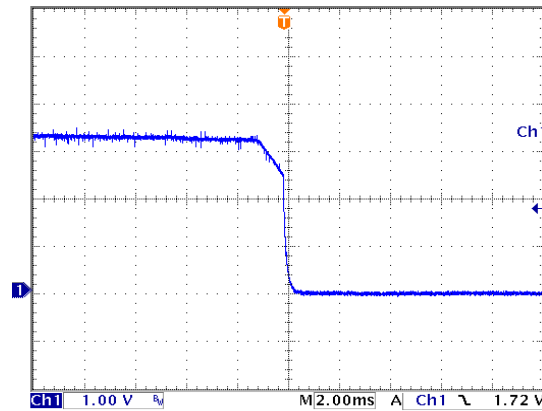

Efficiency vs Temperature and Current

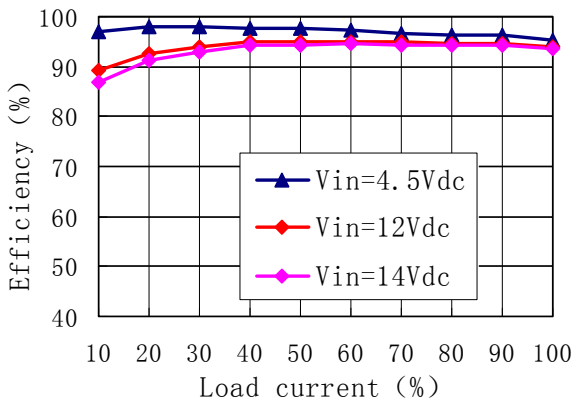

Derating(Vin=12.0Vdc)

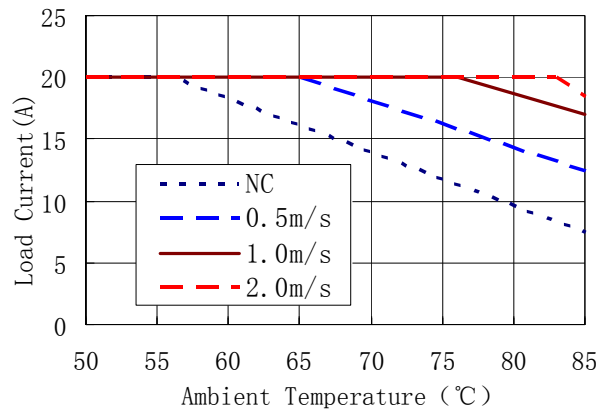

NTB1220DPD 20A Digital Non-isolated DC-DC Converters

Input 4.5V~14V, Output 0.6V~3.3V/20A, Dual-in-line Package

Design Considerations

Basic Connection

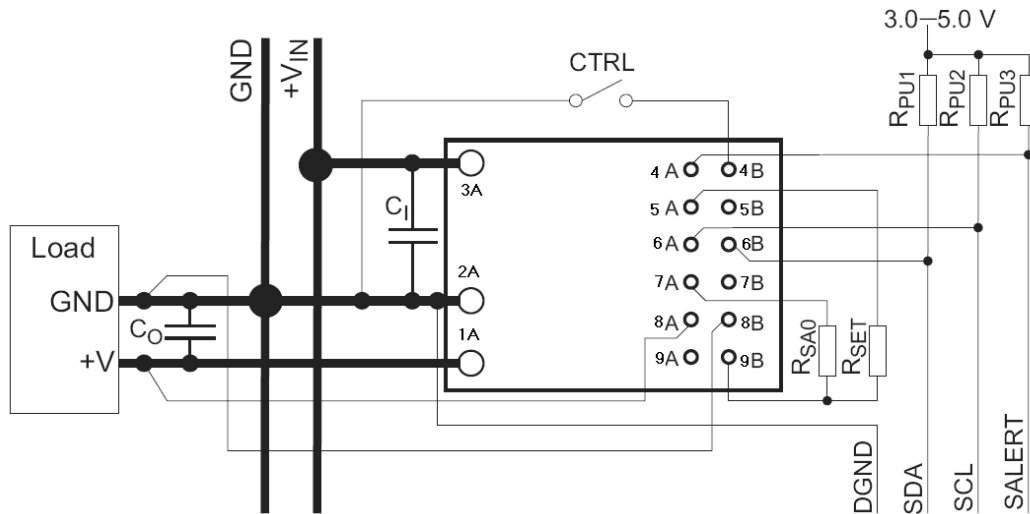

Notes: ①C₁, C_o : 470μF/10mΩ filter capacitor.

②Please see the application information followed for the further information.

Recommended Layout

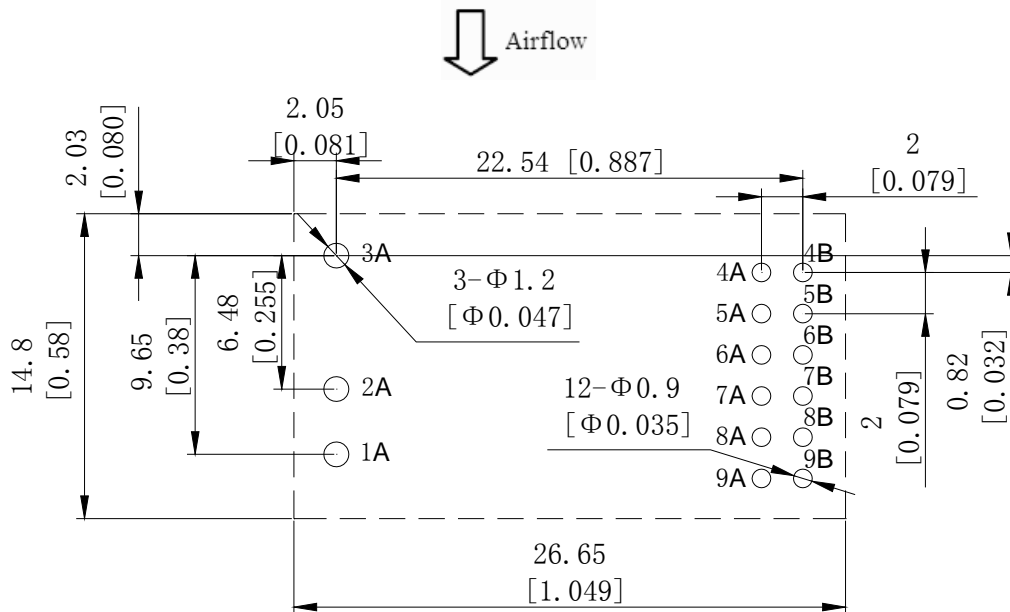

All dimensions are in mm. Recommended to keep out the dashed lines's area for user PCB-layout.

NO.	Recommendation & Notes
Pad Design	1~3: diameter of the pad holes is 1.2mm, 4A~9B: diameter of the pad holes is 0.9mm. Diameter of pads including holes is 1.4mm in the X direction, 1.4mm in the Y direction at least.
Airflow Direction	Shown as the figure
Electric	The Vin(-) and Vo(-) planes should be placed under of the converter separately. Avoid routing sensitive signal or high disturbance AC signal under the converter.

NTB1220DPD 20A Digital Non-isolated DC-DC Converters

Input 4.5V~14V, Output 0.6V~3.3V/20A, Dual-in-line Package

The Ripple Test

The connection diagram for the ripple test is shown on the right: the probe of oscilloscope is docked at the middle position of 10 μ F and 0.1 μ F capacitance, that is the position of A and B. The 50mm wire is equivalent to a small inductor and consists of a filter with two capacitors.

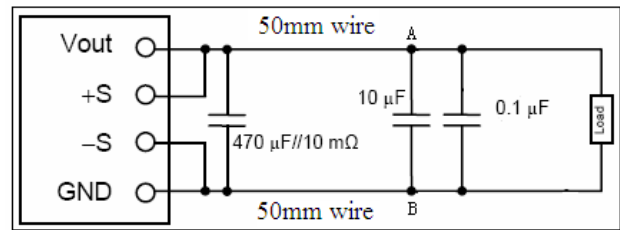

The Ripple Test Diagram

Input Voltage Range

The input voltage range of the product is 4.5V to 14.0V. Because this product belongs to switching power supply, the input of switching power supply is negative impedance, so for the stability of the system, the AC impedance of power supply equipment is required to be as low as possible. Input filter capacitor equidistant, as close as possible to the input pin. The minimum input capacitance is 470 μ F and the equivalent resistance is less than or equal to 10 m Ω .

Input Under Voltage Protection

The product has the function of input under-voltage protection, the factory default under-voltage protection point is 3.85V, under-voltage recovery point is 4.2 V, under-voltage hysteresis is 0.35 V, once the input under-voltage fault occurs, the product will make the following responses:

1. Continue to work, if the input voltage continues to decrease, the module will automatically shut down.
2. Delay for a period of time before the shutdown, until the under-voltage fault disappears and the module returns to normal.
3. Turn off immediately until the under-voltage fault disappears and the module returns to normal. This is the factory default mode.

Remote Control

Remote control can be offered by applying the correct control level (or floating, high resistance) to the CTRL pin. When the level CTRL pin applied is less than 0.8V, the converter will be off. When the level CTRL pin applied is more than 2V and less than 6.5V, the converter will be on. This is the default remote control status of the converter. The range of external levels in the figure is 2V~6.5V.

The remote control function of the product can also be set through the PMBus to control the converters' off and on.

The circuit diagram is shown as "external remote control wiring diagram".

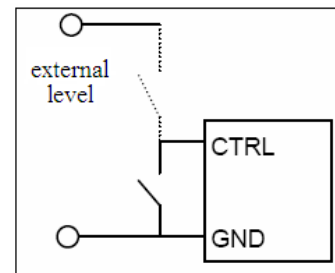

external remote control wiring diagram

External Capacitance

Unless special purposes (i.e. prolonging hold-up time, input impedance matching), the recommended input capacitance range is 470 μ F to 1000 μ F, which not only provide a stable operation, and reduce the cost, but also lessen the inrush current when the power supplies. In order to obtain a small output ripple, the input and output filter capacitors should be located as close as possible to the respective pins.

When larger capacitance is required, a circuit of suppressing the inrush current is recommended when the regulator start-up and a discharge circuit is recommended when the output dropped, ensuring the reliability and safety of other equipments in the system.

Optimization of the Transient Load Response

This product combines the nonlinear transient response-NLR function to reduce loop response time and voltage offset voltages during load transients. The NLR function generates a higher equivalent loop bandwidth in the dynamic response than the traditional linear control loop. The factory configured appropriate parameters of NLR make the product loop stable when the input and output voltage range is very wide. Using the NLR will reduce the capacitance of the external output capacitors, which can reduce costs, but it will also leads to decreased the efficiency of the product, please pay attention to it in application. NLR functional parameters can be modified by modifying the PMBus.

NTB1220DPD 20A Digital Non-isolated DC-DC Converters

Input 4.5V~14V, Output 0.6V~3.3V/20A, Dual-in-line Package

Output Voltage Adjust

Resistor Adjust:

By connecting a external resistor between VSET and PREF, the output voltage can be adjusted from 0.6V to 3.3V. As shown in the output voltage setting diagram, the external resistance configuration table shows the required resistance value, we recommend a resistance of 1% or 0.5% accuracy. By setting the VSET pin, the output voltage can be set to three fixed voltages, as shown in the output voltage setting table.

Vout(V)	Rset(kΩ)	Vout(V)	Rset(kΩ)
0.60	10	1.50	46.4
0.65	11	1.60	51.1
0.70	12.1	1.70	56.2
0.75	13.3	1.80	61.9
0.80	14.7	1.90	68.1
0.85	16.2	2.00	75
0.90	17.8	2.10	82.5
0.95	19.6	2.20	90.9
1.00	21.5	2.30	100
1.05	23.7	2.50	110
1.10	26.1	3.00	121
1.15	28.7	3.30	133
1.20	31.6		
1.25	34.8		
1.30	38.3		
1.40	42.2		

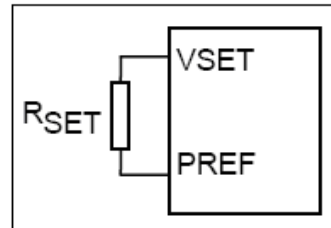

The Output Voltage Setting Diagram

Vout(V)	VSET
0.6	connect with PRET
1.2	floating
2.5	connect with logic high level(be relative to GND)

PMBus Resistor Adjust:

The output voltage can also be set by PMBus in the range of 0.6V~3.3V.

Output Voltage Range Limit:

The maximum output voltage set by PMBus is limited by the external resistor RSET between VSET and PREF, which sets the module's maximum output voltage. You can not set a voltage higher than the limit of the external resistance through PMBus.

Output Over Voltage Protection

In order to protect the load, the product has the output over voltage protection function, the factory default over voltage protection point is 1.15 times of the output voltage,the over voltage protection point can be set by PMBus,the setting ranges are 1.0 to 1.15 times of the output voltage.When the output voltage exceeds the over voltage point, the module can make the following different responses to meet the different needs of customers:

- (1) Turn off the output directly until the output voltage can be restored to the over voltage point below, customers have the option of having the module do several restarts and then shut down.
- (2) The upper rectifier mosfet is off and the lower freewheel mosfet is on until the module is restarted.The default output over voltage protection mode of the module is the second, the device constantly check the existence of the fault, when the fault disappeared ,the device restart. When the synchronous function is used, only the first mode can be used.

The Switching Frequency

The default output switching frequency of the module is 320 kHz, but the switching frequency of the module can

NTB1220DPD 20A Digital Non-isolated DC-DC Converters

Input 4.5V~14V, Output 0.6V~3.3V/20A, Dual-in-line Package

be set by PMBus in the range of 220 kHz to 640 kHz.

The Current Sharing

The module has the function of the current sharing. The function can be used by the modules's GCB end connected together, and set to enable it. The specific connection diagram as shown in the right diagram. The DDC in the diagram is the module's output pin GCB.

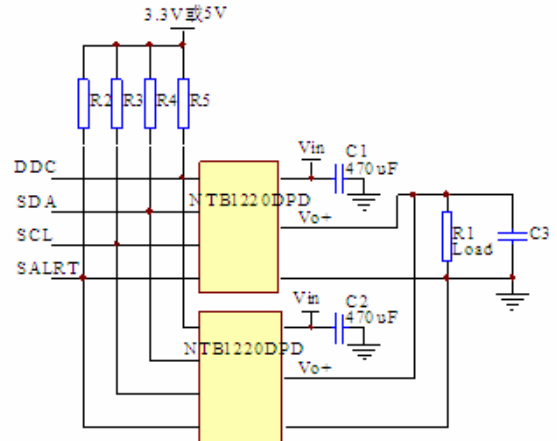

Current sharing connection diagram

Output Over Current Protection

The module has the function of over-current protection function, the factory default over-current point of the module is 26A, it is recommended that the user in the use of the setting range does not exceed 26A. The over-current point and over-current response mode of the product can be modified by PMBus.

Over Temperature Protection

The module has the function of over-temperature protection by using the chip's internal temperature sensor. The module factory default settings are as follows: when the chip's internal temperature exceeds 105°C, the module turn off. After that, the product will continue to try to start up and resume the normal operation; When the internal temperature of the chip drops by 15°C, namely the internal temperature of the chip drops below 90°C, the chip will automatically resume normal operation. The overtemperature protection point can be set up to 120°C and down to minus 40°C, including the worst possible environment and input and output conditions. The protection point, hysteresis and response mode of over-temperature protection can be modified by PMBus. There are several ways to respond to an error:

- (1) Try an infinite number of restarts after the overtemperature protection with a preset delay period before every restart. This method is also factory setup.
- (2) Several restarts are attempted after the over-temperature protection with a preset delay period between restarts. If the temperature is within the overtemperature range, the output is restarted continuously, and if the temperature is below the overtemperature recovery point, the output is re-established.
- (3) If the fault still exists after several cycles of the module, the output is turned off.
- (4) Continue to work (this may cause permanent damage to the module) .
- (5) Turn off immediately after failure.

The PMBus Interface

This product provides a PMBus digital interface to support the user to configure the product parameters and monitor the products' input/output voltage, output current and module internal temperature. This product can be used on any standard IIC or SMBus host two-wire device. In addition, the module is compatible with PMBus version 1.1 and includes a SALERT line to help alleviate bandwidth limitations associated with continuous failure monitoring. The product supports only 100 kHz bus clock frequency, and the SCL, SDA, and SALERT of the PMBus need to be connected with pull resistors as described above for basic application wiring. The rising time of the pull-up resistance must be guaranteed as follows: $T=RC \leq 1 \mu s$. Where R represents the pull-up resistance, C represents the bus capacitive load, the maximum allowable bus capacitive load is 400pF, and the pull-up resistance needs to be connected to an external power supply in the range of 2.7V to 5.5V, the external power supply must be stable before the module is powered on. Otherwise it is possible to pull up the resistance voltage, resulting in unstable communication.

The PMBus Monitoring Function

The product can monitor its own various parameters by the PMBus interface, fault can be monitored by the SALERT pin. When an error or warning occurs in any system configuration, the SALERT pin causes an interrupt and gives an alarm signal. The PMBus function continuously monitors the following module parameters:

- (1) The input voltage;
- (2) The output voltage;
- (3) The output current;
- (4) Internal junction temperature of the main chip;
- (5) The switching frequency;
- (6) The duty cycle.

The PMBus Address

The product's PMBus address configuration requires an external resistor to be connected between SA0 and PREF.

NTB1220DPD 20A Digital Non-isolated DC-DC Converters

Input 4.5V~14V, Output 0.6V~3.3V/20A, Dual-in-line Package

The PMBus address setting wiring diagram is shown as follow. When multiple products are used in parallel, each device must have its own unique address. The PMBus address setting table is shown as follow.

The low level in the PMBus address setting table refers to that SA1 or SA0 and PREF are short circuited. The high level refers to the GND as the reference terminal of the high level. If the above address is not enough, you need to set RSA0 under the condition that the chip's SA1 is grounded. As shown in the PMBus address resistance setting table, you can get 25 separate device addresses by setting RSA0.

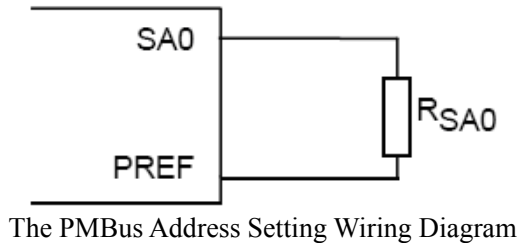

The PMBus Address Setting Table

		SA0		
		Low level	High impedance	High level
SA1	Low level	0X20	0X21	0X22
	High impedance	0X23	0X24	0X25
	High level	0X26	0X27	—

The PMBus Address Resistance Setting Table

RSA0	Communication Address	RSA0	Communication Address
10	0X00	34.8	0X0D
11	0X01	38.3	0X0E
12.1	0X02	42.2	0X0F
13.3	0X03	46.4	0X10
14.7	0X04	51.1	0X11
16.2	0X05	56.2	0X12
17.8	0X06	61.9	0X13
19.6	0X07	68.1	0X14
21.5	0X08	75	0X15
23.7	0X09	82.5	0X16
26.1	0X0A	90.9	0X17
28.7	0X0B	100	0X18
31.6	0X0C		

The PMBus Commands

The product uses the PMBus Power Management bus. The table below lists the PMBus command name, instruction address, and whether it can be implemented. See the PMBus Power System Management Protocol specification; the Part I-General Requirements about details. See the PMBus Power System Management protocol; Part II-Command Language about the communication and electrical interfaces. The Cmd in the table indicate the instruction address and the Impl indicate that whether the instruction can be implemented in the product.

NTB1220DPD 20A Digital Non-isolated DC-DC Converters

Input 4.5V~14V, Output 0.6V~3.3V/20A, Dual-in-line Package

Designation	Cmd	Impl
Control Commands		
PAGE	00h	No
OPERATION	01h	Yes
ON_OFF_CONFIG	02h	Yes
WRITE_PROTECT	10h	No
Output Commands		
VOUT_MODE (Read Only)	20h	Yes
VOUT_COMMAND	21h	Yes
VOUT_TRIM	22h	Yes
VOUT_CAL_OFFSET	23h	Yes
VOUT_MAX	24h	Yes
VOUT_MARGIN_HIGH	25h	Yes
VOUT_MARGIN_LOW	26h	Yes
VOUT_TRANSITION_RATE	27h	Yes
VOUT_DROOP	28h	Yes
MAX_DUTY	32h	Yes
FREQUENCY_SWITCH	33h	Yes
IOUT_CAL_GAIN	38h	Yes
IOUT_CAL_OFFSET	39h	Yes
VOUT_SCALE_LOOP	29h	No
COEFFICIENTS	30h	No
Fault Limit Commands		
POWER_GOOD_ON	5Eh	Yes
VOUT_OV_FAULT_LIMIT	40h	Yes
VOUT_UV_FAULT_LIMIT	44h	Yes
IOUT_OC_FAULT_LIMIT	46h	Yes
IOUT_UC_FAULT_LIMIT	4Bh	Yes
OT_FAULT_LIMIT	4Fh	Yes
OT_WARN_LIMIT	51h	Yes
UT_WARN_LIMIT	52h	Yes
UT_FAULT_LIMIT	53h	Yes
VIN_OV_FAULT_LIMIT	55h	Yes
VIN_OV_WARN_LIMIT	57h	Yes
VIN_UV_WARN_LIMIT	58h	Yes
VIN_UV_FAULT_LIMIT	59h	Yes
VOUT_OV_WARN_LIMIT	42h	No
VOUT_UV_WARN_LIMIT	43h	No
IOUT_OC_WARN_LIMIT	4Ah	No
Fault Response Commands		
VOUT_OV_FAULT_RESPONSE	41h	Yes
VOUT_UV_FAULT_RESPONSE	45h	Yes
OT_FAULT_RESPONSE	50h	Yes

Designation	Cmd	Impl
UT_FAULT_RESPONSE	54h	Yes
VIN_OV_FAULT_RESPONSE	56h	Yes
VIN_UV_FAULT_RESPONSE	5Ah	Yes
IOUT_OC_FAULT_RESPONSE	47h	No
IOUT_UC_FAULT_RESPONSE	4Ch	No
Time setting Commands		
TON_DELAY	60h	Yes
TON_RISE	61h	Yes
TOFF_DELAY	64h	Yes
TOFF_FALL	65h	Yes
TON_MAX_FAULT_LIMIT	62h	No
Status Commands (Read Only)		
CLEAR_FAULTS	03h	Yes
STATUS_BYTE	78h	Yes
STATUS_WORD	79h	Yes
STATUS_VOUT	7Ah	Yes
STATUS_IOUT	7Bh	Yes
STATUS_INPUT	7Ch	Yes
STATUS_TEMPERATURE	7Dh	Yes
STATUS_CML	7Eh	Yes
STATUS_MFR_SPECIFIC	80h	Yes
Monitor Commands (Read Only)		
READ_VIN	88h	Yes
READ_VOUT	8Bh	Yes
READ_IOUT	8Ch	Yes
READ_TEMPERATURE_1	8Dh	Yes
READ_TEMPERATURE_2	8Eh	No
READ_FAN_SPEED_1	90h	No
READ_DUTY_CYCLE	94h	Yes
READ_FREQUENCY	95h	Yes
Identification Commands (Read Only)		
PMBUS_REVISION	98h	Yes
MFR_ID	99h	Yes
MFR_MODEL	9Ah	Yes
MFR_REVISION	9Bh	Yes
MFR_LOCATION	9Ch	Yes
MFR_DATE	9Dh	Yes
MFR_SERIAL	9Eh	Yes
Group Commands		
INTERLEAVE	37h	Yes

NTB1220DPD 20A Digital Non-isolated DC-DC Converters

Input 4.5V~14V, Output 0.6V~3.3V/20A, Dual-in-line Package

Designation	Cmd	Impl
Supervisory Commands		
STORE_DEFAULT_ALL	11h	Yes
RESTORE_DEFAULT_ALL	12h	Yes
STORE_USER_ALL	15h	Yes
RESTORE_USER_ALL	16h	Yes
Product Specific Commands		
Time Setting Commands		
POWER_GOOD_DELAY	D4h	Yes
Fault limit Commands		
IOUT_AVG_OC_FAULT_LIMIT	E7h	Yes
IOUT_AVG_UC_FAULT_LIMIT	E8h	Yes
Fault Response Commands		
MFR_IOUT_OC_FAULT_RESPOSE	E5h	Yes
MFR_IOUT_UC_FAULT_RESPOSE	E6h	Yes
OVUV_CONFIG	D8h	Yes

Designation	Cmd	Impl
Configuration and Control Commands		
MFR_CONFIG	D0h	Yes
USER_CONFIG	D1h	Yes
MISC_CONFIG	E9h	Yes
PID_TAPS	D5h	Yes
INDUCTOR	D6h	Yes
NLR_CONFIG	D7h	Yes
TEMPCO_CONFIG	DCh	Yes
DEADTIME	DDh	Yes
DEADTIME_CONFIG	DEh	Yes
DEADTIME_MAX	BFh	Yes
SNAPSHOT	EAh	Yes
SNAPSHOT_CONTROL	F3h	Yes
DEVICE_ID	E4h	Yes
USER_DATA_A_00	B0h	Yes
Group Commands		
SEQUENCE	E0h	Yes
GCB_GROUP	E2h	Yes
ISHARE_CONFIG	D2h	Yes
PHASE_CONTROL	F0h	Yes

The Software Tools

Our company provides the product configurations and monitoring software to the uses, please contact sales about the specific details.

Thermal Consideration

The regulators are designed to operate between -40°C~85°C, and sufficient cooling must be provided to ensure reliable operation. The relationship between regulators mounting direction and airflow direction should be cared in PCB design for users (please refer the airflow direction shown as recommended layout),and make sure the highest heating components (the inductor) is apart from the other parts more than 1mm, in order to ensure good heat dissipation of the power components, The airflow speed choice refers to derating curves at different output voltage.Special instruction:natural cooling means that the airflow speed is less than or equal to 0.1m/s.Example:when applying: the input voltage is 12V, the output voltage is 3.3V, the temperature is 65°C, the airflow speed is greater than or equal to 0.5m/s when full load use.

The over-temperature test point P1 is shown in the figure.P1 is a chip,the temperature is 120°C after derating.

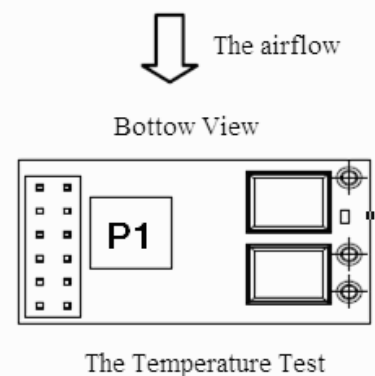

Delivery Package Information

Package material is multiple wall corrugated, internal material is anti-static foam, it's surface resistance is from 10⁵ Ω to 10¹² Ω.Tray capacity: 8×3=24 PCS/box,Tray weight: 0.31kg; Carton capacity: 810 PCS,Carton weight:4.62kg.

Quality Statement

The converters are manufactured in accordance with ISO 9001 system requirements, in compliant with

NTB1220DPD 20A Digital Non-isolated DC-DC Converters**Input 4.5V~14V, Output 0.6V~3.3V/20A, Dual-in-line Package**

YD/T1376-2005, and are monitored 100% by auto-testing system, 100% burn in.

The warranty for the converters is 5-year.

Contact Information

Anhui Hesion Trading Co.,Ltd.

& Beijing Yihongtai Technology Dev. Co.,Ltd.

TEL:+86-551-65369069,65369067

Email: alecz@ahhesion.com

Backup:alecz@126.com

www.ahhesionpower.com