

NTB1210 Series Non-isolated DC-DC Converters

Input 4.5V-14V, Output 0.59V-5.1V/10A, Single-in-line Package

Contents

Features.....	1
Ordering Information.....	1
Outline Diagram	2
Specifications.....	2
Characteristic Curves (Vo=0.59V)	4
Characteristic Curves (Vo=1.0V)	5
Characteristic Curves (Vo=1.2V)	6
Characteristic Curves (Vo=1.8V)	7
Characteristic Curves (Vo=2.5V)	8
Characteristic Curves (Vo=3.3V)	9
Characteristic Curves (Vo=5.0V)	10
Design Considerations.....	11
Basic Connection.....	11
Recommended Layout.....	11
Input Voltage Range.....	12
Remote Control.....	12
External Capacitance	12
Output Voltage Adjust.....	12
Over Temperature Protection (OTP).....	13
Thermal Consideration	13
Delivery Package Information.....	13
Quality Statement	13



POL converters
NTB1210 Series

Features

- Package 10.4mm×16.5mm×10.2mm
- Remote On/Off (positive logic)
- Output Voltage Range : 0.59V to 5.1V
- High Efficiency, 95% type (Input: 12.0V , output:5.0V)
- Over Temperature Protection
- Operating Temperature: -40 to 85
- Max Load Current: 10A
- Application: Telecommunication equipments、 data exchange servers and distributed power architectures

Ordering Information

See Contents for individual product ordering numbers.

Suffix	Description	Ordering No.
P	Positive logic	NTB1210P
V	The output voltage set-point, e.g. the output voltage of NTB1210-1V2 is 1.2V.	NTB1210P *V*
N	Negative logic	NTB1210N

NTB1210 Series Non-isolated DC-DC Converters

Input 4.5V-14V, Output 0.59V-5.1V/10A, Single-in-line Package

Outline Diagram

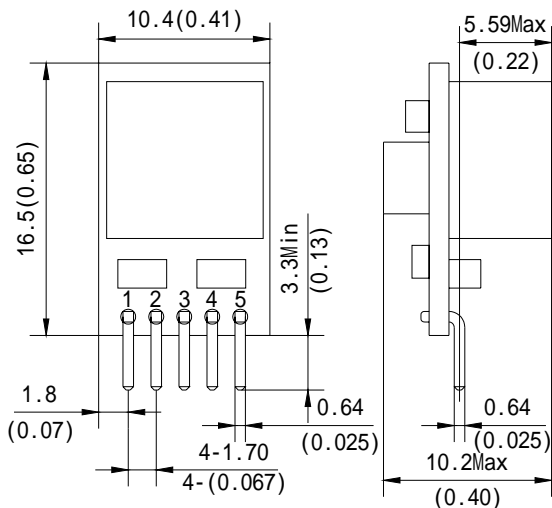

Pin	Symbol	Function
1	TRIM	Output voltage adjust pin.
2	Vo	Positive output pin.
3	GND	Common ground for input and output.
4	Vin	Positive input pin.
5	CNT	Remote Control Pin.

PCB Material: Multilayer PCB,
Pin: copper with tin plating.

Notes: all dimensions in mm(inches)

Tolerances : X.X ± 0.5 (X.XX ± 0.02)
X.XX ± 0.25 (X.XXX ± 0.010)

Specifications

Unless otherwise specified, all values are given at: 25 °C, standard atmosphere pressure, pure resistive load. When testing, 22µF ceramic capacitor and 100µF tantalum capacitor are required to be connected to input and output pins separately.

Input		Symbol	Min	Typ	Max	Unit	Conditions
Input Voltage		V _{in}	4.5	12.0	14.0	V	V _O ≤ 3.63V
			6.5	12.0	14.0	V	0.59V ≤ V _O ≤ 5.10V
CNT (Positive Logic)	Input current	-	-	-	0.5	mA	CNT sink current when converter turn on
	On	-	4.3	-	14	V	Refer to GND ; Also turn on when CNT floating.
	Current	-	-	-	0.5	mA	CNT source current when converter shutdown
	Off	-	0	-	0.2	V	Refer to GND
Under Voltage Threshold		V _{UVLO}	1.6	-	2.9	V	-

Output		Symbol	Min	Typ	Max	Unit	Conditions
Output Voltage		V _O	0.59	-	5.10	V	See "Input Voltage"
Output Current		I _O	0	-	10	A	-
Line Regulation		S _V	-	-	±5	mV	V _O ≤ 1.8V , I _O = 10A
			-	-	±10	mV	1.8V < V _O ≤ 2.5V , I _O = 10A
			-	-	±0.5	%V _O	V _O > 2.5V , I _O = 10A
Load Regulation		S _I	-	-	±10	mV	V _{in} = 12V , V _O ≤ 1.8V
			-	-	±15	mV	V _{in} = 12V , 1.8V < V _O ≤ 2.5V
			-	-	±0.5	%V _O	V _{in} = 12V , V _O > 2.5V

NTB1210 Series Non-isolated DC-DC Converters

Input 4.5V-14V, Output 0.59V-5.1V/10A, Single-in-line Package

Continue

Output		Symbol	Min	Typ	Max	Unit	Conditions	
Current Limit Inception		$I_{O,lim}$	12	-	-	A	$V_{in}=12V$	
Peak to Peak Ripple and Noise		V_{pp}	-	-	50	mV	20MHz bandwidth	
Output Short-circuit Protection		cycle by cycle protected , auto-recovery , recommended short circuit protection time < 2 hour						
Rise Time		T_{rise}	-	-	70	ms	$I_{O,nom}$, pure resistive load	
Start-up Delay Time		T_{delay}	-	-	50	ms	$I_{O,nom}$, pure resistive load	
Capacitive Load Range		C_O	0	-	8400	μF	$V_o=0.59V$	
			0	-	8400	μF	$V_o=1.0V$	
			0	-	6000	μF	$V_o=1.2V$	
			0	-	3000	μF	$V_o=1.8V$	
			0	-	2500	μF	$V_o=2.5V$	
			0	-	1100	μF	$V_o=3.3V$	
			0	-	1100	μF	$V_o=5.0V$	
Load Transient	Recovery Time	t_{tr}	-	25	50	μs	$V_o:0.59 \sim 5.0V$	
	Voltage Deviation	V_{tr}	-	± 70	-	mV	$V_o=0.59V$	
			-	± 50	-	mV	$V_o=1.0V$	
			-	± 50	-	mV	$V_o=1.2V$	
			-	± 55	-	mV	$V_o=1.8V$	
			-	± 60	-	mV	$V_o=2.5V$	
			-	± 100	-	mV	$V_o=3.3V$	
-	± 100	-	mV	$V_o=5.0V$				

50% ~ 100% $I_{o,max}$
2.5A/ μs

General	Symbol	Min	Typ	Max	Unit	Conditions
Efficiency	η	-	95	-	%	$V_{in}=12V$, 10A , $V_o=5.0V$
		-	92	-	%	$V_{in}=12V$, 10A , $V_o=3.3V$
		-	90	-	%	$V_{in}=12V$, 10A , $V_o=2.5V$
		-	87	-	%	$V_{in}=12V$, 10A , $V_o=1.8V$
		-	83	-	%	$V_{in}=12V$, 10A , $V_o=1.2V$
		-	80	-	%	$V_{in}=12V$, 10A , $V_o=1.0V$
		-	73	-	%	$V_{in}=12V$, 10A , $V_o=0.59V$
Switching Frequency	f_s	-	600	-	kHz	—
MTBF	-	5×10^6	-	-	h	BELLCORE TR-332,
Operating Temperature	-	-40	-	+85		—
Storage Temperature	-	-55	-	+125		—
Relative Humidity	-	10	-	90	%	40 \pm 2 , No condensing

NTB1210 Series Non-isolated DC-DC Converters

Input 4.5V-14V, Output 0.59V-5.1V/10A, Single-in-line Package

Continue

General	Symbol	Min	Typ	Max	Unit	Conditions
Temperature Coefficient	ST	—	—	±0.02	%/	—
Over Temperature Protection Reference Point	Tref	95	105	125		The specific test point for OTP : See application information section
Hand Soldering	Maximum soldering Temperature < 425 , and duration < 5s					
Wave Soldering	Maximum soldering Temperature < 255 , and duration < 10s					
Weight	-	-	4	-	g	—

Characteristic Curves (Vo=0.59V)

Load Transient Response

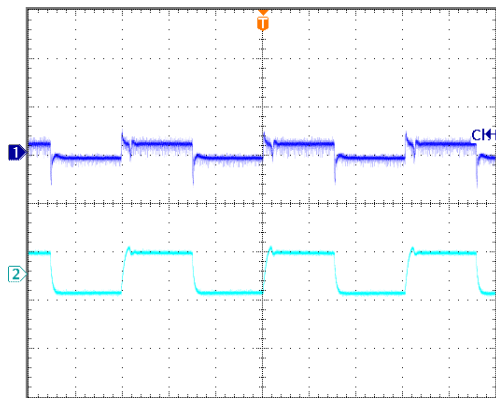

Load change:50% ~ 100% Trace1: 50mV/div
 Io,nom, 2.5A/μs Trace2: 6A/div
 Vin=12Vdc Time scale: 0.4ms/div

Output Ripple

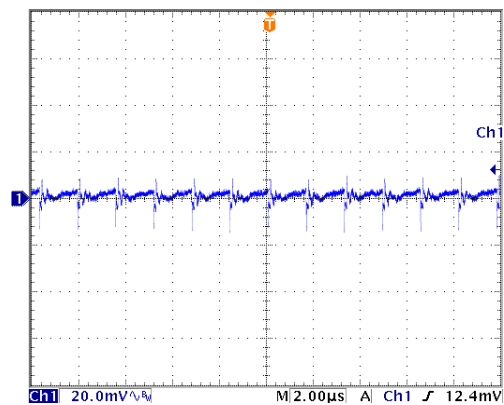

Vin=12V , Io=10A

Start-up Delay Time

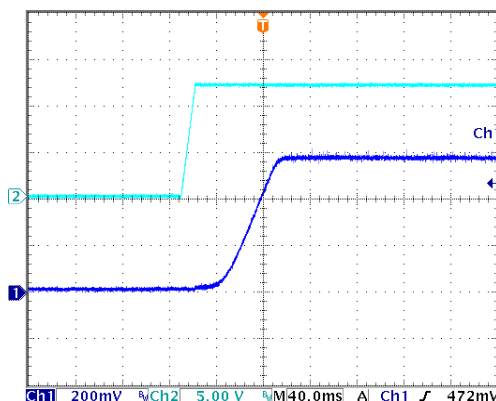

Vin=12V , Io=10A

Turn-off

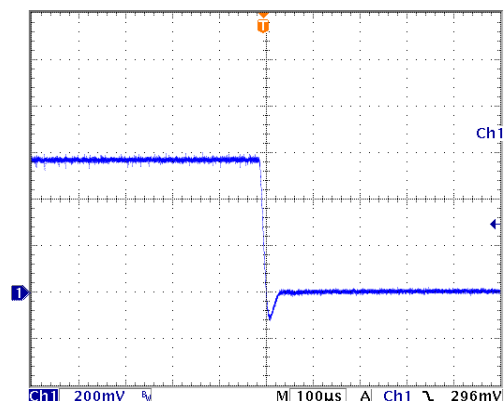

Vin=12V , Io=10A

NTB1210 Series Non-isolated DC-DC Converters

Input 4.5V-14V, Output 0.59V-5.1V/10A, Single-in-line Package

Efficiency vs. Io & Ambient Temp

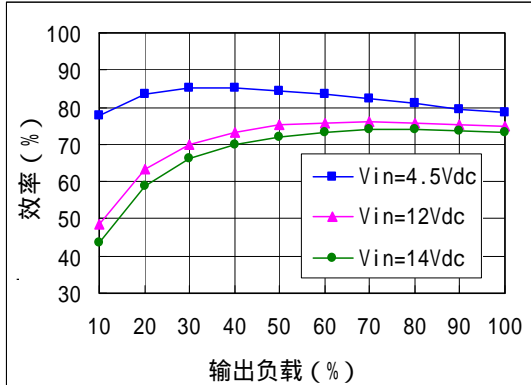

Vin=12V , Io=10A , resistive load

Derating

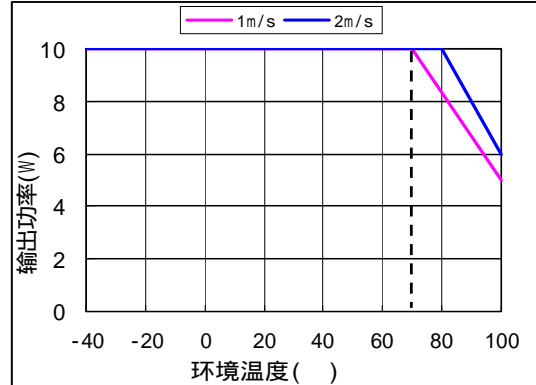

Vin=12V

Characteristic Curves (Vo=1.0V)

Load Transient Response

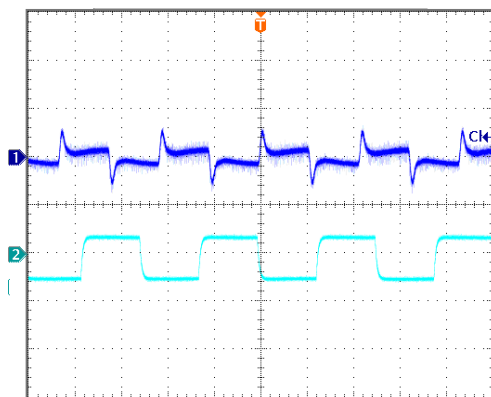

Load change: 50% ~ 100% Trace1: 50mV/div
 Io,nom, 2.5A/μs Trace2: 6A/div
 Vin=12Vdc Time scale: 0.4ms/div

Output Ripple

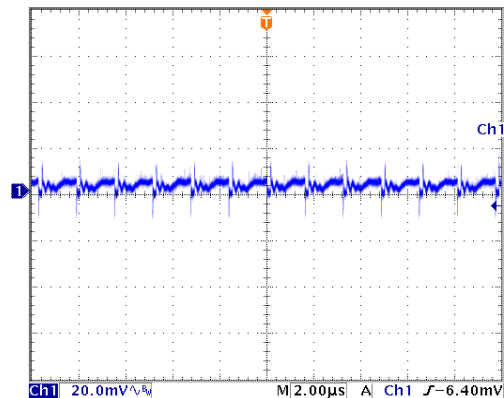

Vin=12V , Io=10A

Start-up Delay Time

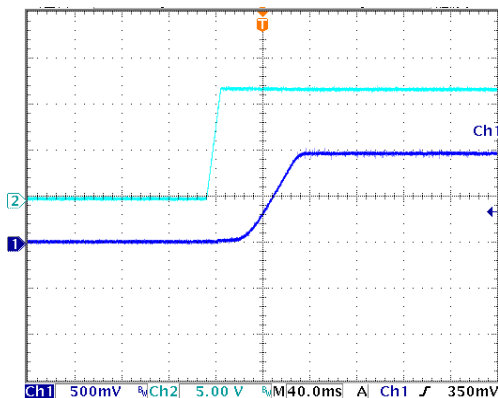

Vin=12V , Io=10A

Turn-off

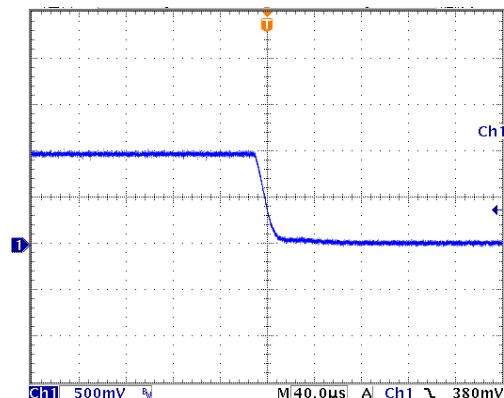

Vin=12V , Io=10A

NTB1210 Series Non-isolated DC-DC Converters

Input 4.5V-14V, Output 0.59V-5.1V/10A, Single-in-line Package

Efficiency vs. Io & Ambient Temp

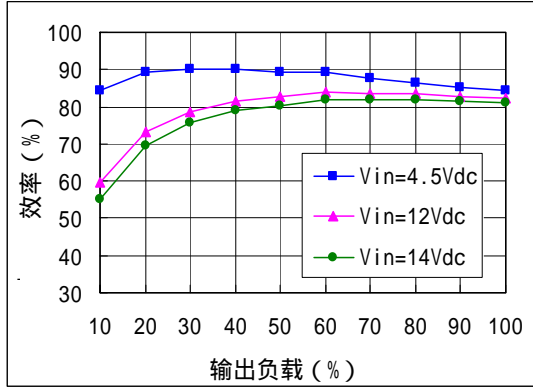

Vin=12V , Io=10A , resistive load

Derating

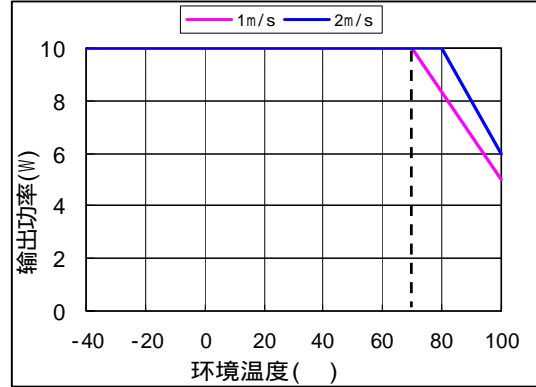

Vin=12V

Characteristic Curves (Vo=1.2V)

Load Transient Response

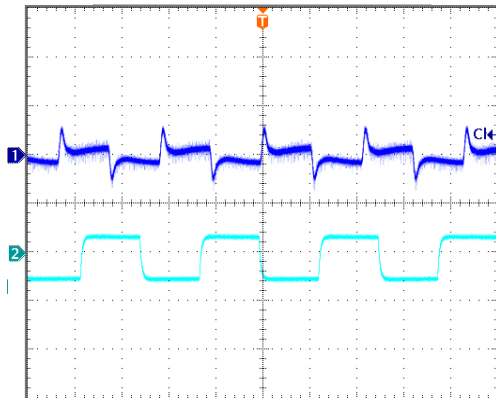

Load change:50% ~ 100% Trace1: 50mV/div
 Io,nom, 2.5A/μs Trace2: 6A/div
 Vin=12Vdc Time scale: 0.4ms/div

Output Ripple

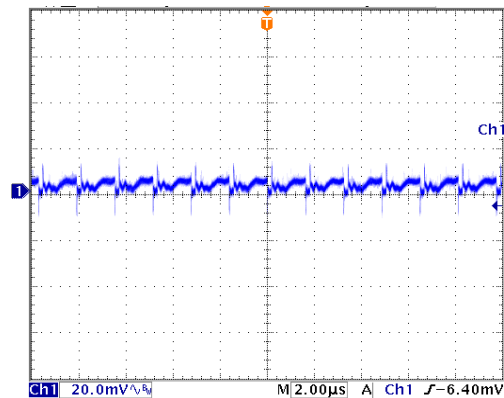

Vin=12V , Io=10A

Start-up Delay Time

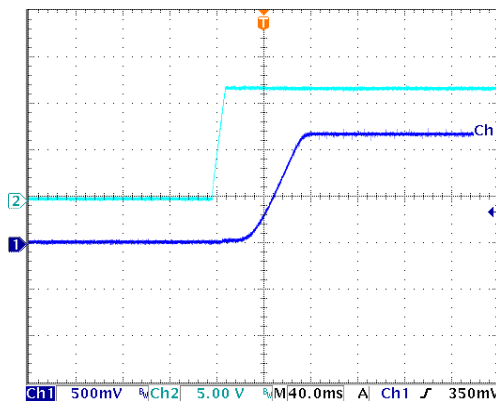

Vin=12V , Io=10A

Turn-off

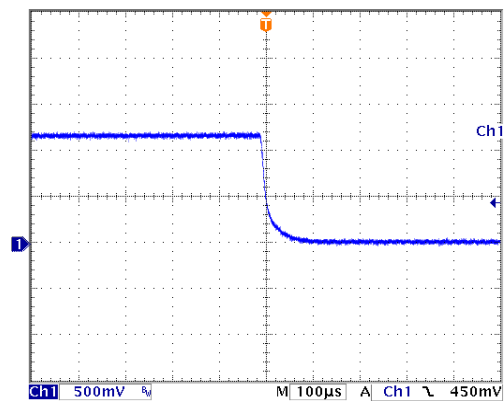

Vin=12V , Io=10A

NTB1210 Series Non-isolated DC-DC Converters

Input 4.5V-14V, Output 0.59V-5.1V/10A, Single-in-line Package

Efficiency vs. Io & Ambient Temp

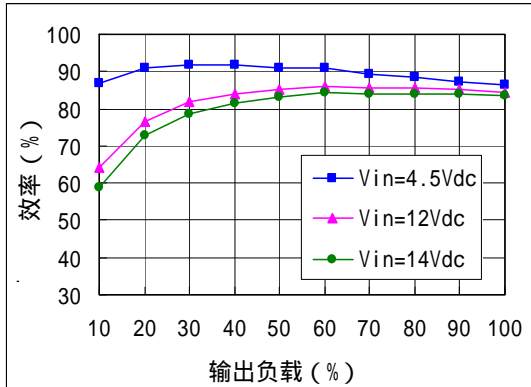

Vin=12V , Io=10A , resistive load

Derating

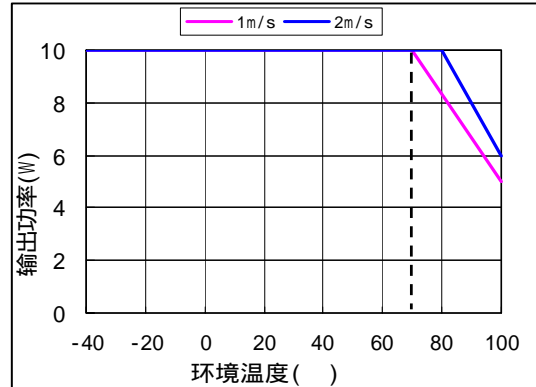

Vin=12V

Characteristic Curves (Vo=1.8V)

Load Transient Response

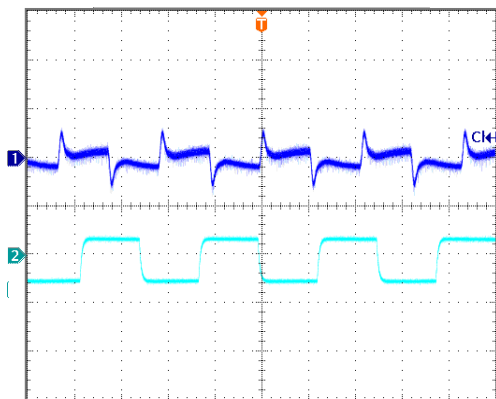

Load change:50% ~ 100% Trace1: 50mV/div
 Io,nom, 2.5A/μs Trace2: 6A/div
 Vin=12Vdc Time scale: 0.4ms/div

Output Ripple

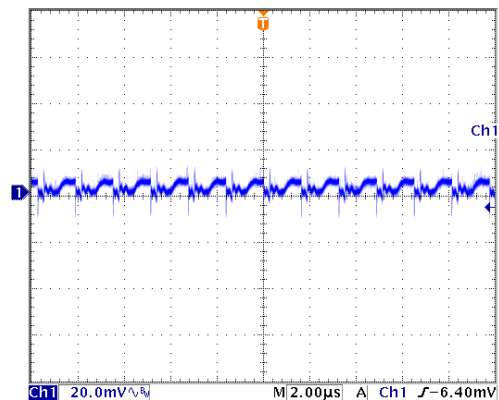

Vin=12V , Io=10A

Start-up Delay Time

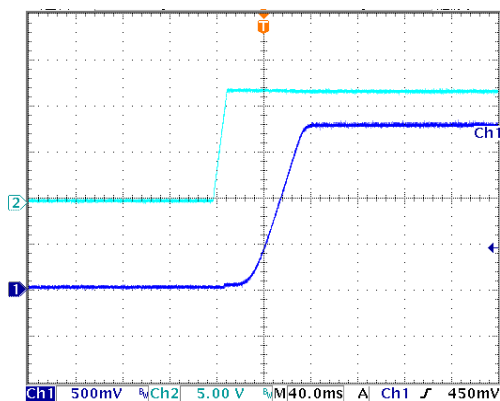

Vin=12V , Io=10A

Turn-off

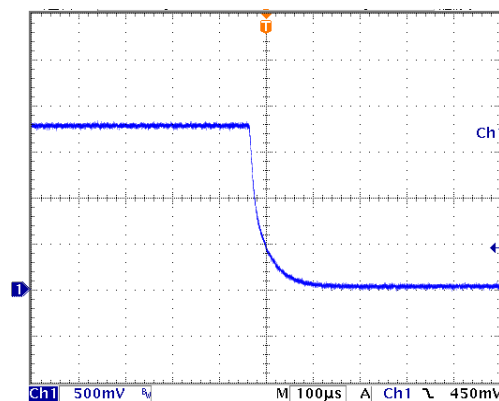

Vin=12V , Io=10A

NTB1210 Series Non-isolated DC-DC Converters

Input 4.5V-14V, Output 0.59V-5.1V/10A, Single-in-line Package

Efficiency vs. Io & Ambient Temp

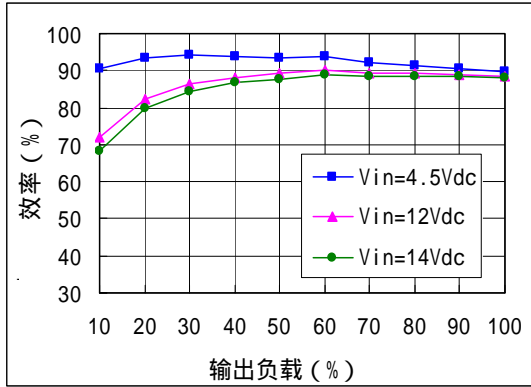

Vin=12V , Io=10A , resistive load

Derating

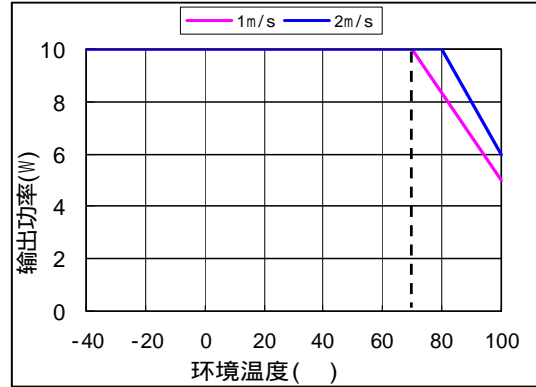

Vin=12V

Characteristic Curves (Vo=2.5V)

Load Transient Response

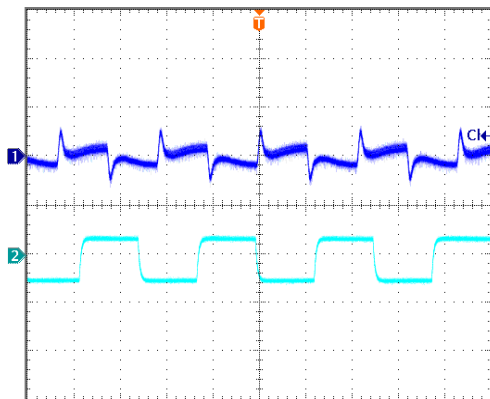

Load change:50% ~ 100% Trace1: 50mV/div
Io,nom, 2.5A/μs Trace2: 6A/div
Vin=12Vdc Time scale: 0.4ms/div

Output Ripple

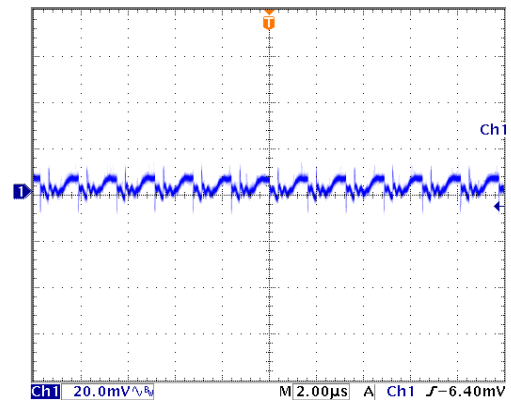

Vin=12V , Io=10A

Start-up Delay Time

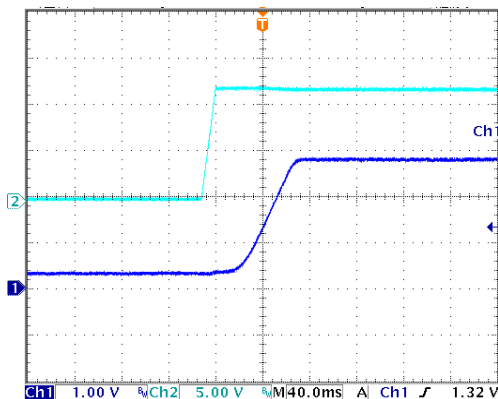

Vin=12V , Io=10A

Turn-off

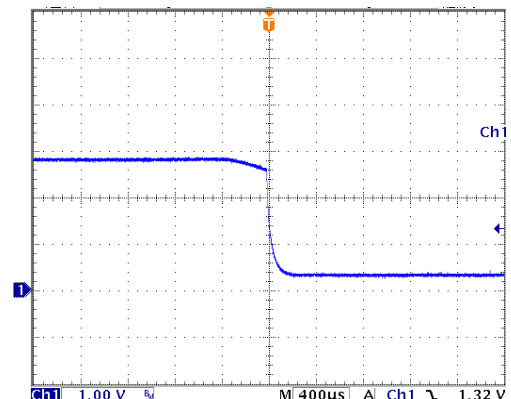

Vin=12V , Io=10A

NTB1210 Series Non-isolated DC-DC Converters

Input 4.5V-14V, Output 0.59V-5.1V/10A, Single-in-line Package

Efficiency vs. Io & Ambient Temp

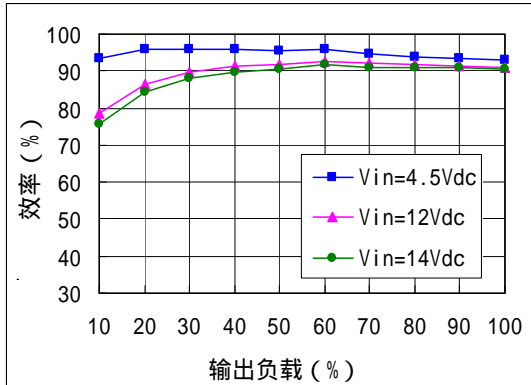

Vin=12V , Io=10A , resistive load

Derating

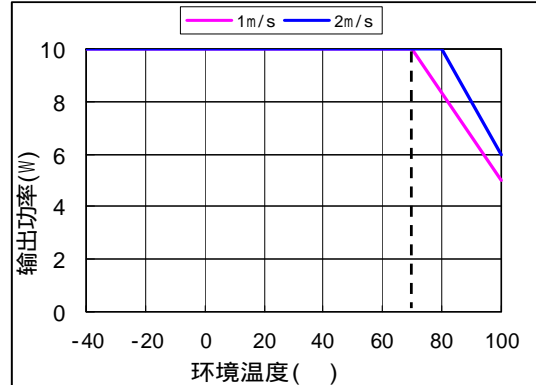

Vin=12V

Characteristic Curves (Vo=3.3V)

Load Transient Response

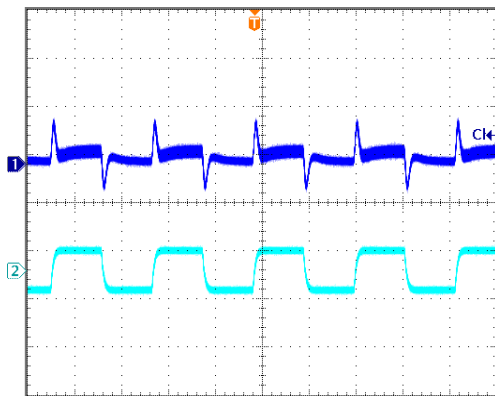

Load change:50% ~ 100% Trace1: 50mV/div
 Io,nom, 2.5A/μs Trace1: 50mV/div
 Vin=12Vdc Time scale: 0.4ms/div

Output Ripple

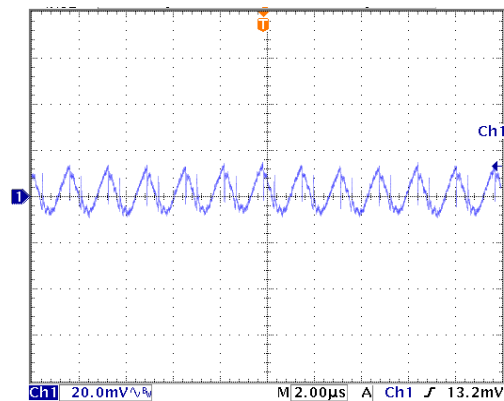

Vin=12V , Io=10A

Start-up Delay Time

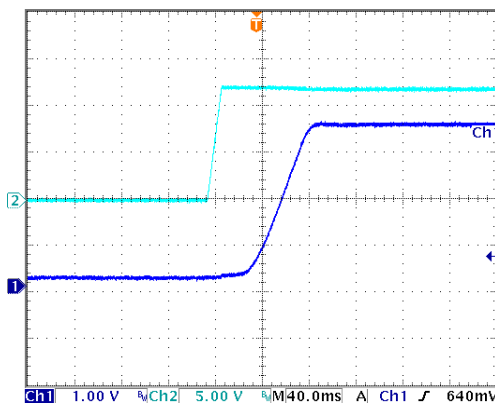

Vin=12V , Io=10A

Turn-off

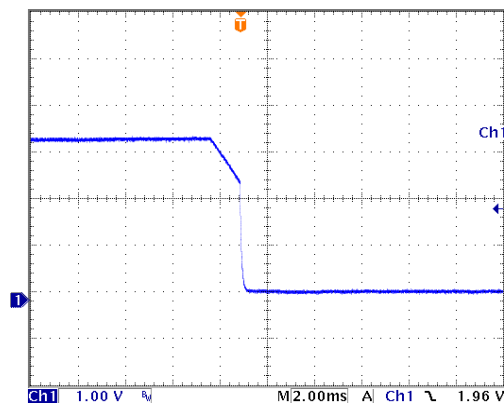

Vin=12V , Io=10A

NTB1210 Series Non-isolated DC-DC Converters

Input 4.5V-14V, Output 0.59V-5.1V/10A, Single-in-line Package

Efficiency vs. Io & Ambient Temp

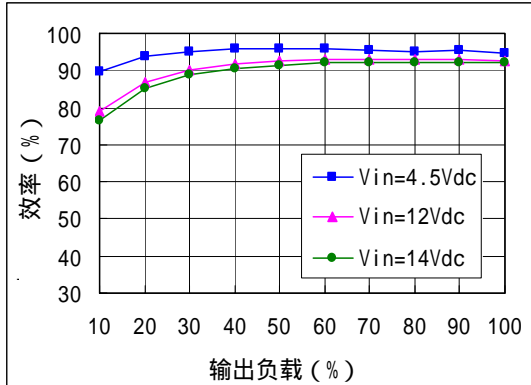

Vin=12V , Io=10A , resistive load

Derating

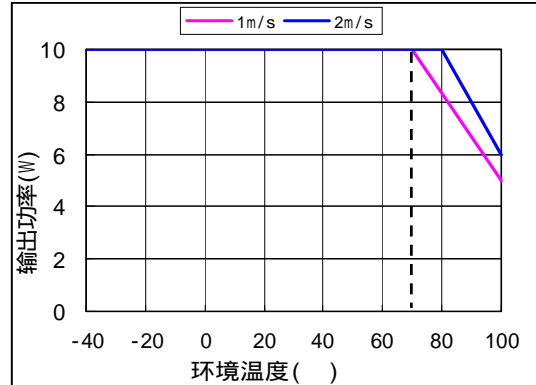

Vin=12V

Characteristic Curves (Vo=5.0V)

Load Transient Response

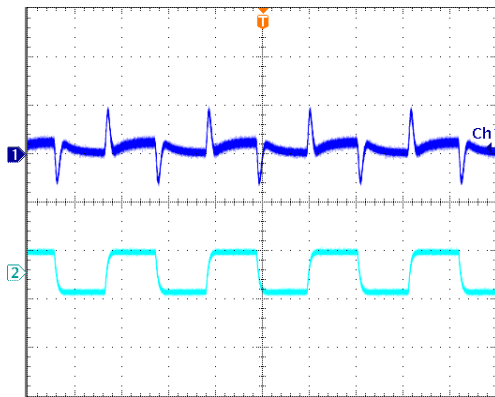

Load change:50% ~ 100% Trace1: 50mV/div
 Io,nom, 2.5A/μs Trace2: 6A/div
 Vin=12Vdc Time scale: 0.4ms/div

Output Ripple

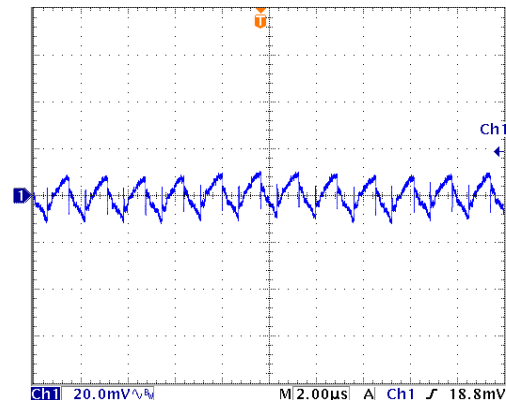

Vin=12V , Io=10A

Start-up Delay Time

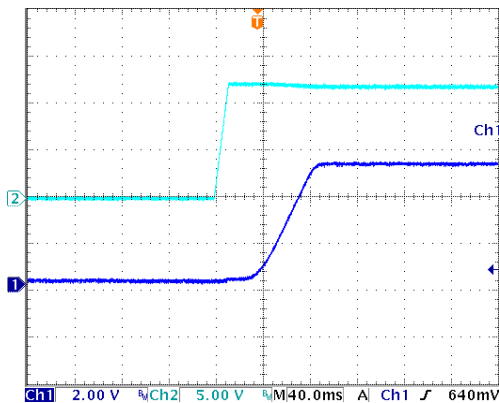

Vin=12V , Io=10A

Turn-off

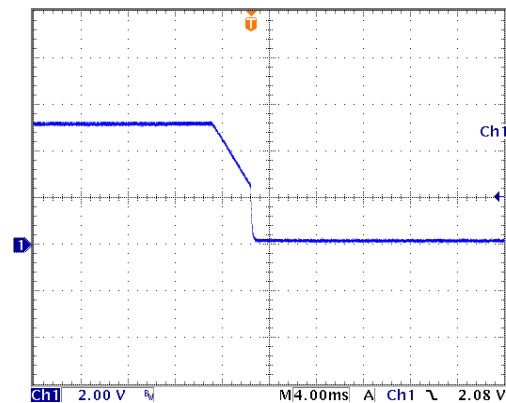

Vin=12V , Io=10A

NTB1210 Series Non-isolated DC-DC Converters

Input 4.5V-14V, Output 0.59V-5.1V/10A, Single-in-line Package

Efficiency vs. Io & Ambient Temp

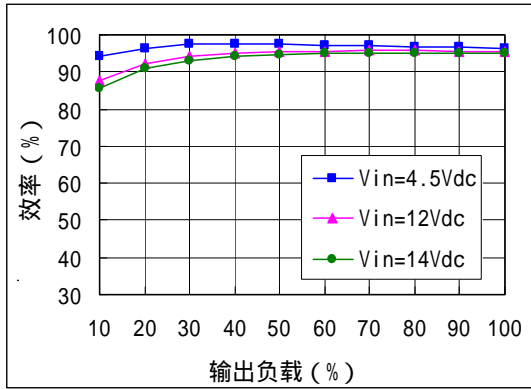

Vin=12V , Io=10A , resistive load

Derating

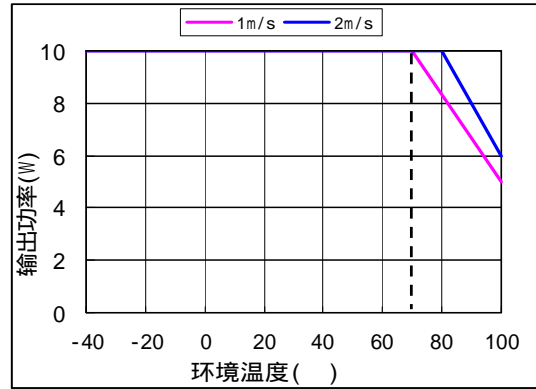

Vin=12V

Design Considerations

Basic Connection

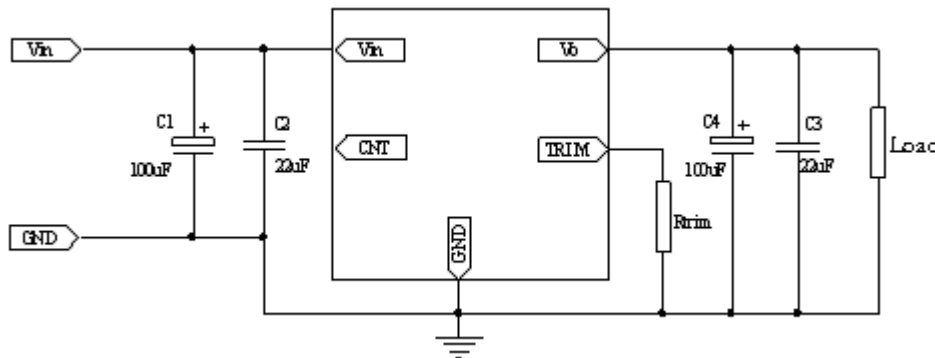

Notes: Please see the application information followed for the further information.

Recommended Layout

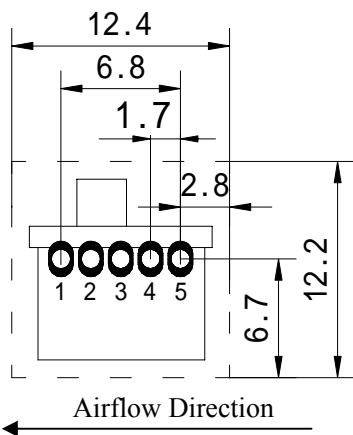

All dimensions are in mm.

Recommended to keep out the dashed lines's area for user PCB-layout.

NO.	Recommendation & Notes
Pad Design	1-5Pad holes : 1.0mm, pad diameter including hole : ≥1.4mm in X axis and ≥2.0mm in Y axis
Airflow Direction	Shown as the figure
Electric	The Vin(-) and Vo(-) planes should be placed under of the converter separately. Avoid routing sensitive signal or high disturbance AC signal under the converter.

NTB1210 Series Non-isolated DC-DC Converters

Input 4.5V-14V, Output 0.59V-5.1V/10A, Single-in-line Package

Input Voltage Range

The Input voltage range of the regulator is 4.5V to 14V. The input impedance of the regulator looks like a negative resistor, which can interact with the reactance of the power bus (including any filter elements that have been added to the input of the regulator), causes an unstable condition. The AC impedance of the regulator should be as low as possible to ensure stable operation. The input filter capacitors should be paralleled equidistantly and connected as close as possible to the input pins. When more than one converters are paralleled, a inductor of 0.2μH to 0.5μH should be equipped to separate the noise between converters and prevent from interference each other. The minimum capacitance for the filter capacitor is 100μF.

Remote Control

Remote control can be offered by setting right control voltage level (or floating) to CNT pin. When the level is less than 0.2V, the converter will be off. When the level is higher than 4.3 V or floating, the converter will be on.

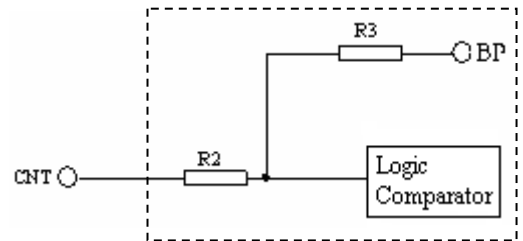

Remote Control Circuit Diagram

The circuit diagram is shown as “Remote Control Circuit Diagram”, when the low level applied, the converter consumes tiny leakage current, which can be considered no power dissipation.

External Capacitance

Unless special purposes (i.e. prolonging hold-up time, input impedance matching), the recommended input capacitance range is 100μF to 1000μF, which not only provide a stable operation, and reduce the cost, but also lessen the inrush current when the power supplies.

When larger capacitance is required, a circuit of suppressing the inrush current is recommended when the regulator start-up and a discharge circuit is recommended when the output dropped, ensuring the reliability and safety of other equipments in the system.

Output Voltage Adjust

Resistor Adjust :

The output voltage can be set from 0.59V to 5.10V by adjusting the resistance of Rtrim , the formula for the

resistance as follows:
$$R_{trim} = \frac{1.182}{(V_o - 0.591)}$$

For the resistance listed in Table 1, the resistors with 1% or 0.5% accuracy are recommended.

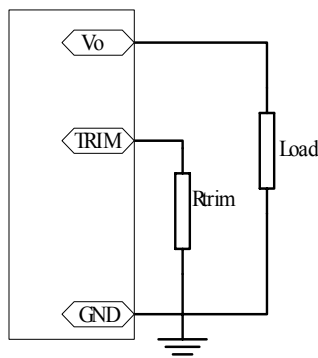

Table 1 The external Resistance	
Output Voltage (V)	Calculation (KΩ)
0.59	open
1.0	2.890
1.2	1.941
1.8	0.978
2.5	0.619
3.3	0.436
5.0	0.268
5.1	0.262

NTB1210 Series Non-isolated DC-DC Converters

Input 4.5V-14V, Output 0.59V-5.1V/10A, Single-in-line Package

Over Temperature Protection (OTP)

The regulators are protected from thermal overload by an internal over temperature shutdown circuit. When the PCB temperature (reference point A, see the figure below) exceeds the temperature trig point (95 °C), the OTP circuit will cut down output power. The regulator will stop until safe operating temperature is restored. Time between OTP and restart is dependent on cooling of the regulator.

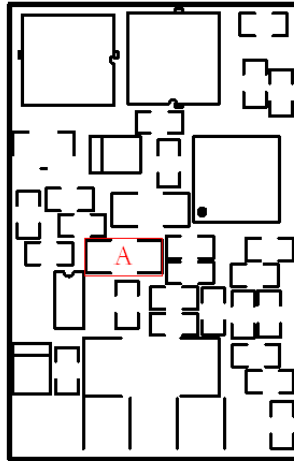

Thermal Consideration

The regulators are designed to operate between -40°C ~ 85°C, and sufficient cooling must be provided to ensure reliable operation. The relationship between regulators mounting direction and airflow direction should be cared in PCB design for users (please refer the airflow direction shown as recommended layout), and make sure the highest heating components (the inductor) is apart from the other parts more than 1mm, in order to ensure good heat dissipation of the power components, The airflow speed choice refers to derating curves at different output voltage.

Delivery Package Information

Package material is multiple wall corrugated, internal material is anti-static foam, its surface resistance is from $10^5 \Omega$ to $10^{12} \Omega$. Tray capacity: $50 \times 2 = 100$ PCS/box, Tray weight: 0.42kg;
Carton capacity: $100 \times 15 = 1500$ PCS, Carton weight: 6.5kg.

Quality Statement

The converters are manufactured in accordance with ISO 9001 system requirements, in compliant with YD/T1376-2005, and are monitored 100% by auto-testing system, 100% burn in.
The warranty for the converters is 5-years.