

RAGS25-24A05 DC-DC Converters

Input 16V~40V, Output 5V/5A, One Sixteen Standard Brick

Contents

Features 1
 Ordering Information 1
 Contact Information 1
 Outline Diagram 2
 Specification 2
 Characteristic Curves 5
 Design Considerations 7
 Basic Connection 7
 Recommended Layout 8
 Input Voltage Range 8
 Output Voltage Adjust 8
 External Capacitance 9
 Remote Control 10
 Remote Sense 10
 Over Temperature Protection(OTP) 11
 Output Over Voltage Protection(OVP) 11
 Series and Parallel Operation 11
 Thermal Consideration 11
 Safety Consideration 12
 ESD Control 12
 Cleaning Notice 12
 Delivery Package Information 12
 Quality Statement 13

Features

- ◆ One Sixteen Brick(36.6mm×26.6mm×12.7mm)
- ◆ 2.5 times Input Voltage Range (16V~40V)
- ◆ Input Under Voltage Protection (10V~16V turn off)
- ◆ Input Transient Over Voltage 50V(≤100ms)
- ◆ Positive Logic Control (3.5V~15V or floating turn on)
- ◆ Output Voltage Adjust Range: ±10%V_{o,nom}
- ◆ Output Over Voltage Protection, auto-recovery (5.5V~7.5V)
- ◆ Output Over Current Protection、Short-circuit Protection (Clamped, auto-recovery)
- ◆ High Efficiency up to 92% (24V, full load)
- ◆ 2250Vdc Isolation Voltage
- ◆ Operating Substrate (Case) Temperature -40℃ ~+90℃
- ◆ Over Temperature Protection 115℃Typ.
- ◆ Applications: telecommunication applications, electronic data processing, military industry, industrial control、vehicle and other applications with high quality requirements, distributed power architecture, etc.

DOSA Standard outline



Ordering Information

See Contents for individual product ordering numbers.

Suffix	Description	Ordering No.
--	Shown as the specification	RAGS25-24A05
P	Negative Logic Control: 3.5V~15V or floating, turn off; 0~0.5V, turn on	RAGS25-24A05P

Contact Information

Anhui Hesion Trading Co.,Ltd.
 & Beijing Yihongtai Technology Dev.Co.,Ltd

TEL: +86-551-65369069,65369067
 Email: alecz@ahhesion.com
 Backup:alecz@126.com
www.ahhesionpower.com

RAGS25-24A05 DC-DC Converters

Input 16V~40V, Output 5V/5A, One Sixteen Standard Brick

Outline Diagram

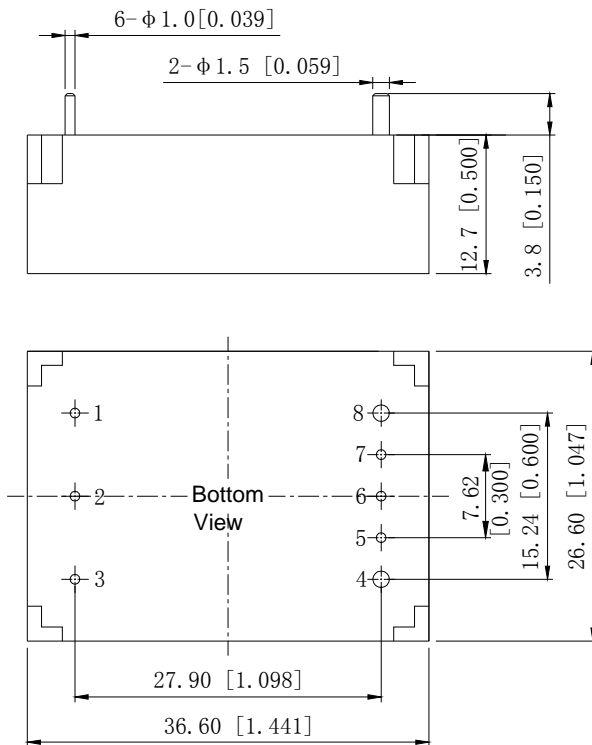

Pin	Symbol	Function
1	-Vin	Negative Input
2	CNT	Remote Control, turn on/off the converter. Output voltage on when CNT floating or high level applied
3	+Vin	Positive Input
4	+Vo	Positive Output
5	+S	Positive Remote Sense, connected to +Vo pin when not in use.
6	TRIM	Output Voltage Trim, voltage be trimmed up or down by applying external resistor connected to +S or -S output
7	-S	Negative Remote Sense, connected to -Vo pin if not used.
8	-Vo	Negative Output

Substrate material: aluminium;
Case and cover material: plastics;
Pin material: brass with gold plated surface.

Notes: All dimensions in mm[inches]
Tolerances: X.X±0.5[X.XX±0.02]
 X.XX±0.25[X.XXX±0.010]
Pin diameter tolerance: ±0.10[±0.004]

Specification

Unless otherwise specified, all tests are at room temperature and standard atmosphere, pure resistive load and basic connection.

Input	Symbol	Min	Typ	Max	Unit	Conditions	
Input Voltage	V_{in}	16	24	40	V	$I_o: 0 \sim 5.0A$	
Maximum Transient Input Voltage	-	-	-	50	V	Transient ≤ 100ms	
Maximum Input Current	$I_{in,max}$	-	-	1.8	A	$V_{in,min}, I_{o,max}$	
Positive Logic Control	On	-	3.5	-	15.0	V	Refer to -Vin; turn on when CNT floating
	Off	-	0	-	0.5	V	Refer to -Vin
Negative Logic Control	On	-	0	-	0.5	V	Refer to -Vin
	Off	-	3.5	-	15.0	V	Refer to -Vin; turn off when CNT floating
Start-up Delay Time	T_{delay}	-	100	-	ms	$V_{in,nom}, I_{o,max}$	
Under Voltage Threshold	V_{UVLO}	10	-	15.8	V	-	
Under Voltage Protection Hysteresis	ΔV_{UVLO}	1	-	3	V	-	

RAGS25-24A05 DC-DC Converters

Input 16V~40V, Output 5V/5A, One Sixteen Standard Brick

Continue

Input	Symbol	Min	Typ	Max	Unit	Conditions
Input Reflected Ripple Current	—	—	50	130	mA	Connect a input inductance of 12μH/3A in series(20MHz)
Input Idling Current	$I_{in,nl}$	—	75	150	mA	$V_{in,nom}, I_o=0A$
Static Input Current	—	—	1	—	mA	CNT pin 0~0.5V, refer to $-V_{in}$

Output	Symbol	Min	Typ	Max	Unit	Conditions	
Output Voltage	V_o	4.95	5.00	5.05	V	—	
Voltage Accuracy	—	—	—	2	% V_o	$V_{in}:16\sim40V; I_o:0\sim5A; -40\text{°C}\sim85\text{°C}$	
Output Current	I_o	0	—	5	A	$V_{in}:16\sim40V$	
Output Power	—	0	—	25	W	$V_{in}:16\sim40V$	
Output Voltage Adjust Range	V_{trim}	4.5	—	5.5	V	Trim up: $P_o\leq25W$; Trim down: $I_o\leq5A$	
Line Regulation	S_V	—	—	±0.3	% V_o	$V_{in}:16V\sim40V, I_{o,max}$	
Load Regulation	S_I	—	—	±0.5	% V_o	$V_{in,nom}, I_o:0\sim5A$	
Output Over Voltage Protection Set Point	$V_{ov,set}$	5.5	—	7.5	V	$V_{in,nom}, P_o\leq25W$ hiccup mode	
Output Over Current Protection Range	$I_{o,lim}$	5.5	—	8.5	A	$V_{in}:16\sim40V, V_{o,nom}$	
Output Short-circuit Protection	hiccup mode ,auto-recovery						
Peak to Peak Ripple and Noise	ΔV_{pp}	—	25	50	mV	20MHz bandwidth, $V_{in}:16\sim40V, I_{o,max}$; A 10μF tantalum capacitor and a 1μF ceramic capacitor are applied at output	
Rise Time	T_{rise}	—	25	—	ms	$V_{in,nom}, I_{o,max}$	
Capacitive Load	C_o	0	—	5000	μF	Pure resistive load	
Remote Sense Compensation Range	V_{sense}	0	—	0.5	V	+S and -S twisted Pair, length is less than 20cm	
Output Overshoot	V_{TO}	0	—	±0.5	V	—	
Load Transient	Recovery Time	t_{tr}	—	—	300	μs	25%~50%~25% $I_{o,nom}$ or 50%~75%~50% $I_{o,nom}$; 0.1A/μs. A 10μF tantalum capacitor and a 1μF ceramic capacitor are applied at output
	Voltage Deviation	ΔV_{tr}	—	—	±250	mV	

General	Symbol	Min	Typ	Max	Unit	Conditions	
Efficiency	η	89	92	—	%	$V_{in,nom}, I_{o,max}$	
Isolation Resistance	Input -Output	R_{iso}	50	—	—	MΩ	Under normal atmospheric pressure, Relative humidity: 90%, Test voltage: 500V _{dc}
	Input -Substrate						
	Output -Substrate						

RAGS25-24A05 DC-DC Converters

Input 16V~40V, Output 5V/5A, One Sixteen Standard Brick

Continue

General		Symbol	Min	Typ	Max	Unit	Conditions
Isolation Voltage	Input-Output	V_{iso}	2250	-	-	Vdc	Time:1min, Leak Current \leq 1mA, No breakdown and arc phenomenon
	Input-Substrate						
	Output-Substrate						
Switching Frequency		-	250	300	350	kHz	—
MTBF		-	2×10^6	-	-	h	BELLCORE TR-332, ambient temperature 40°C
Storage Temperature		-	-45	-	+125	°C	—
Temperature Coefficient		S_T	-	-	± 0.02	%/°C	Ambient temperature -40°C ~ 85°C
Operating Substrate (Case) Temperature		-	-40	-	+90	°C	See the derating curve 1 Forced air cooling or heatsink should be used at high temperature
Operating Ambient Temperature		-	-40	-	+85	°C	See the derating curve 2 Forced air cooling or heatsink should be used at high temperature
Thermal Resistance See the derating curve 3		$R_{\theta CA}$	-	12.2	-	°C/W	Natural Convection
		$R_{\theta CA}$	-	11.1	-	°C/W	100LFM Convection
		$R_{\theta CA}$	-	8.7	-	°C/W	200LFM Convection
		$R_{\theta CA}$	-	7.1	-	°C/W	300LFM Convection
		$R_{\theta CA}$	-	6.3	-	°C/W	400LFM Convection
Over Temperature Protection Reference Point		T_{ref}	-	115	-	°C	See “Over Temperature Protection”
Over Temperature Protection Hysteresis		ΔT_{ref}	-	10	-	°C	
Relative Humidity		-	10	-	90	%	No condensing
Temperature Rise		-	-	35	-	°C	$V_{in,nom}, I_{o,max}$ Without heatsink, under natural heat dissipation conditions
Hand Soldering		Maximum soldering Temperature < 425°C, and duration < 5s					
Wave Soldering		Maximum soldering Temperature < 255°C, and duration < 10s					
Weight		-	-	35	-	g	—

RAGS25-24A05 DC-DC Converters

Input 16V~40V, Output 5V/5A, One Sixteen Standard Brick

Characteristic Curves

Load Transient Response

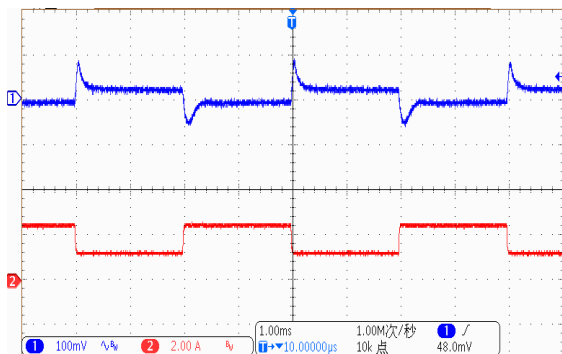

Load change: 25%~50%
 ~25% $I_{o,nom}$, 0.1A/ μ s
 V_{in} =24Vdc
 Trace1: 100mV/div
 Trace2: 2A/div
 Time scale: 1ms/div

Load Transient Response

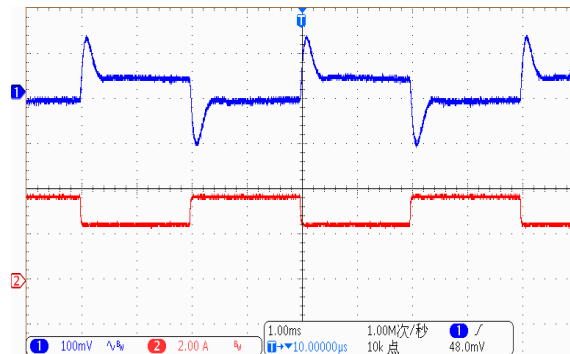

Load change: 50%~75%
 ~25% $I_{o,nom}$, 0.1A/ μ s
 V_{in} =24Vdc
 Trace1: 100mV/div
 Trace2: 2A/div
 Time scale: 1ms/div

Output Ripple and noise

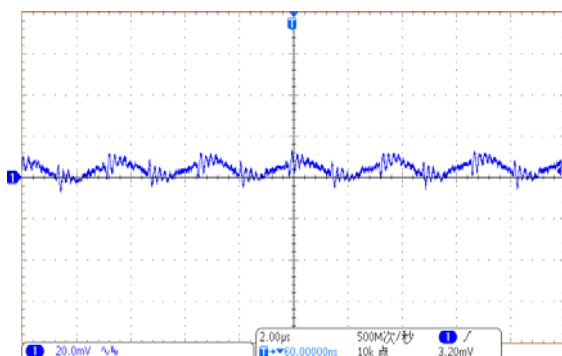

V_{in} =24V, I_o =5A

Start-up Delay Time

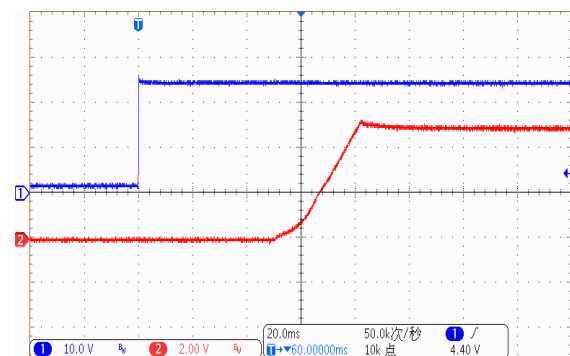

V_{in} =24V, I_o =5A

Rise Time

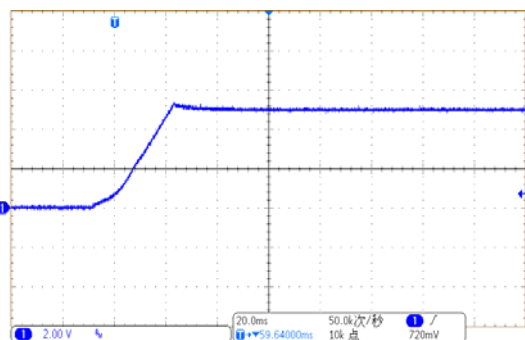

V_{in} =24V, I_o =5A

Turn-off

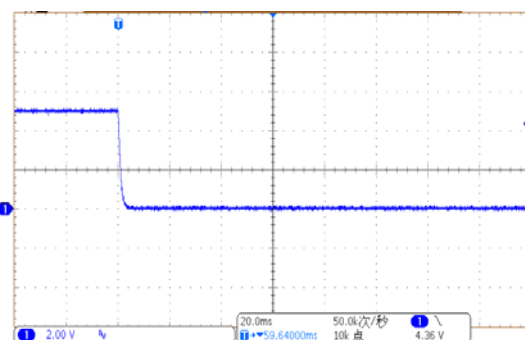

V_{in} =24V, I_o =5A

RAGS25-24A05 DC-DC Converters

Input 16V~40V, Output 5V/5A, One Sixteen Standard Brick

The Derating Curve 1

Forced air cooling or heatsink should be used at high temperature

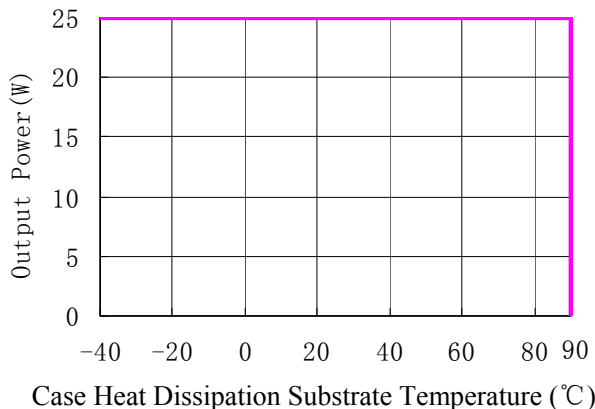

The Derating Curve 2

Forced air cooling or heatsink should be used at high temperature

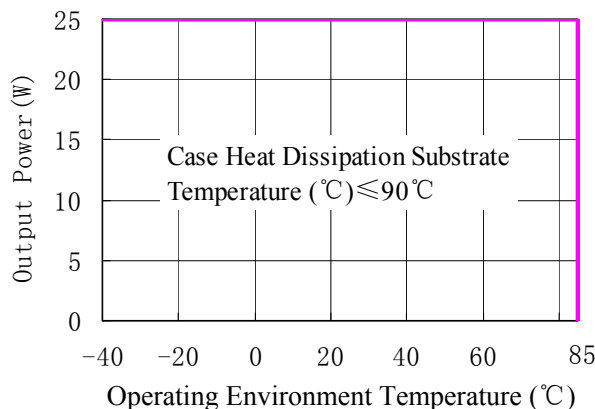

Efficiency vs Temperature and Current

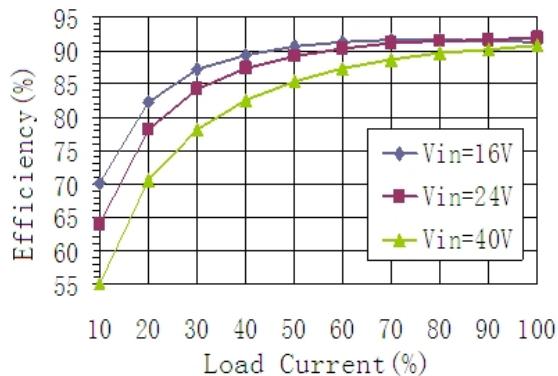

Loss vs Current

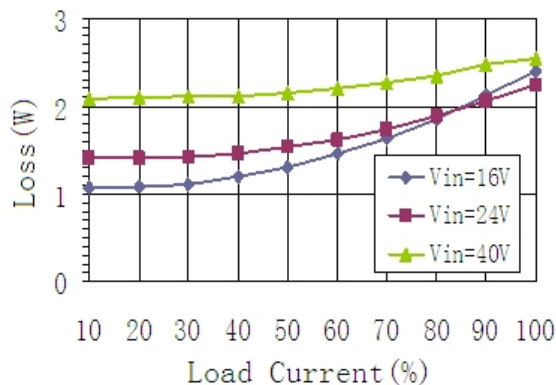

**The Derating Curve 3
(Vin=24V; Without Heatsink)**

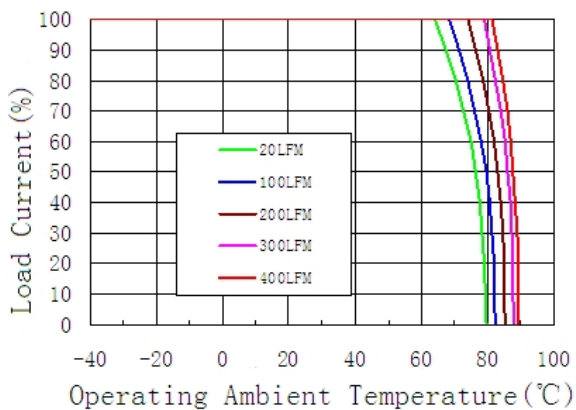

Note: 20LFM (Natural Convection) = 0.1m/s

Volt-ampere Characteristic

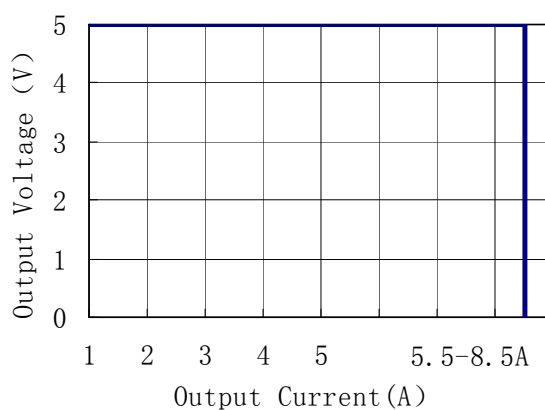

RAGS25-24A05 DC-DC Converters

Input 16V~40V, Output 5V/5A, One Sixteen Standard Brick

Note:

1. During product installation, attention should be paid to the direction of hot air flow to ensure the smooth exchange of heat generated by losses with ambient temperature. From the derating curves 1 and 2 above, it can show us that as long as the temperature of the case heat dissipation substrate does not exceed 90°C, the product can still operate normally with full load within the required environmental temperature range (-40~85 °C). Under certain environmental temperature conditions, users can improve the heat dissipation conditions by increasing the wind speed appropriately or further installing heatsinks on the heat dissipation substrate, thereby expanding the load capacity of the derating curve 3.

2. The derating curve 3 shows the derating curve for different wind speeds without an external heatsink (pins in non welded mode), It can be used as reference materials for thermal design for customers. In practical use, due to factors such as the application environment, cloth board, and wind speed of the module, they are not the same. Please provide sufficient derating during thermal design based on actual usage, which not only effectively prevents the module from entering an over temperature protection state, but also extends the service life of the module.

Design Considerations

Basic Connection

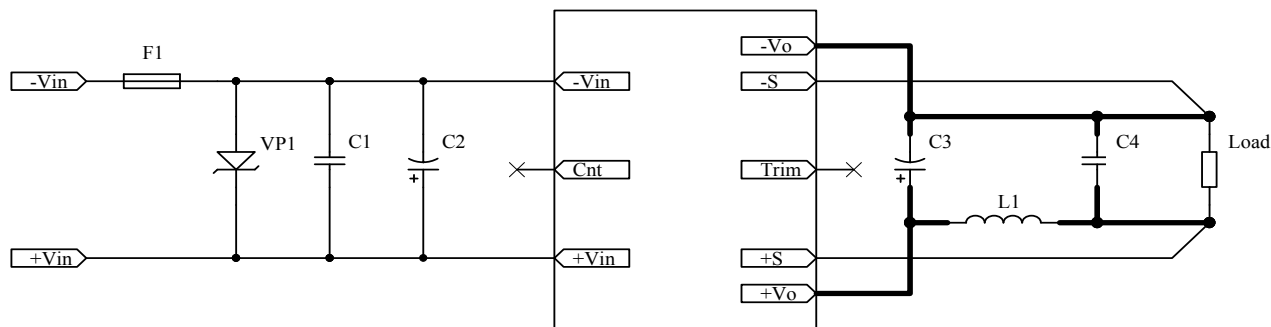

Notes: The basic connection indicates the basic requirements that the power module can provide rated output voltage and rated power only. Please refer the instruction followed for further information.

Part No.	Components	Part No.	Components
F1	Quick break fuse 5A	C3	Electrolytic or solid-state capacitors (-40°C~-50°C、100uF/10V)
VP1	1.5KE43A	L1	Inductance(recommend 0.22~0.33uH and ≥ 8A, which is beneficial for applications that pursue lower ripple requirements) Note: the inductance is not used in the values in the performance parameters
C1	Ceramic capacitor 4.7uF/50V Note: the capacitor is not used in the values in the performance parameters		
C2	Electrolytic or solid-state capacitor (-40 °C~-50 °C、100uF/50V)	C4	Ceramic capacitor or tantalum capacitor 10uF/10V Note: a 10uF/10V tantalum capacitor is used in the value in the performance parameters (More energy storage capacitors can be added according to customer needs)

RAGS25-24A05 DC-DC Converters

Input 16V~40V, Output 5V/5A, One Sixteen Standard Brick

Recommended Layout

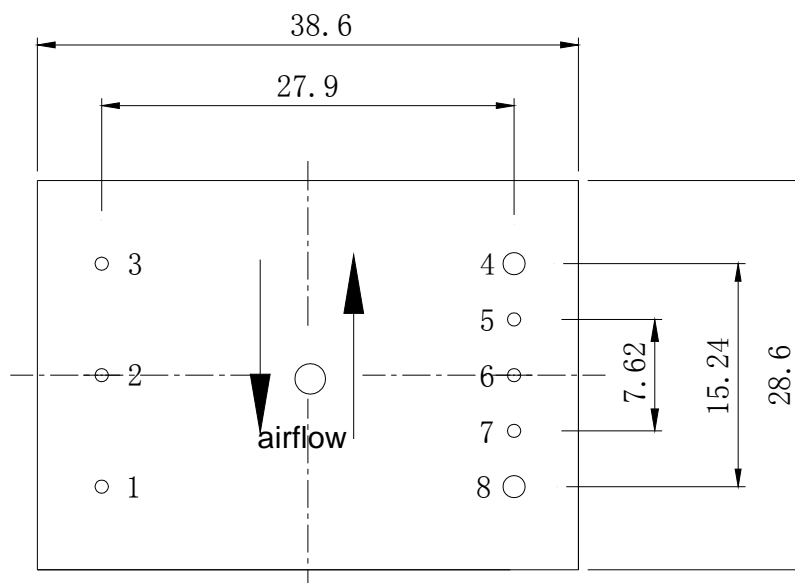

Recommended printed board layout
(Non needle surface, top view)

NO.	Recommendation & Notes
Pad Design	4&8 pad hole diameter is 2.0mm, pad diameter including hole is at least 3.5mm; the rest pad hole diameter is 1.5mm and pad diameter including hole is at least 2.5 mm
Airflow Direction	As the figure shown or the opposite direction, perpendicular direction is not recommended.
Safety	Isolated Converters, care to the spacing between input and output $\geq 2.5\text{mm}$
Electrical	The Vin(-) and Vo(-) planes should be placed under of the converter separately. Avoid routing sensitive signal or high disturbance AC signal under the converter. Due to the large input and output currents, it is recommended that the current density of the wiring connected to the input and output pins is less than $6\text{A}/\text{mm}^2$

Input Voltage Range

The input voltage range of the product is 16V~40V. Continuous input voltage is not allowed to exceed 42V under any conditions, Exceeding the specified input voltage range can lead to product failure. In order to suppress pulse spikes from the input voltage, it is recommended to connect a electrolytic or solid-state capacitor of $\geq 100\mu\text{F}$ at -40°C to -50°C in series at the input end. Due to the fact that this product belongs to a switching power supply, the input of the switching power supply has a negative impedance characteristic. Therefore, in order to ensure the stable operation of the system, it is required that the power supply equipment and power supply lines have a low source impedance. When the input wiring is too long, resulting in a high source impedance, the output voltage or ripple of the module power supply may be unstable. The method to determine whether the impedance of the power bus too high or not is to decrease the converter's input voltage from higher to lower gradually. If the module power supply works normally when the input voltage is high, and the output voltage decreases or becomes unstable when the input voltage is low, and reducing the load current can restore normal, it may be due to high power supply impedance. For further confirmation, a electrolytic capacitor of $100\mu\text{F}/50\text{V}$ can be paralleled to the converter pins after the converter shuts down (in some cases, a ceramic capacitor of $4.7\mu\text{F}/50\text{V}$ may be required to be connected between the electrolytic capacitor and the module pin), if the output is getting better, it will be sure that the impedance of the power supply circuit is too large.

Output Voltage Adjust

The converters have an Output Voltage adjust pin (Trim). This pin can be used to adjust the output voltage

RAGS25-24A05 DC-DC Converters

Input 16V~40V, Output 5V/5A, One Sixteen Standard Brick

above or below Output voltage initial setting. The maximum value of the trimmed up is 10%, even +S and -S pins are used to compensate the voltage simultaneously, the sum of the trimmed up and the compensation should not be more than 10%, or the characteristics will not be assured in compliant with the specification, even the over voltage protection may be triggered. The output power can not exceed 25W at increased output voltages, and the output current can not exceed 5A. When the trim pin is not used, it should be floated. At the same time, the -S pin and the -Vo pin are shorted, the +S pin and the +Vo pin are shorted. External circuit is connected as the figure shown, the resistance is calculated as the formula below, please note that the formula will be invalid when R_{Trim-up}、R_{Trim-down} are used simultaneously, users adjust the value based on the resistance applied.

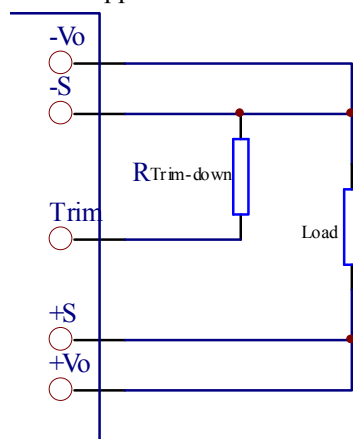

Connection for Trimming Down

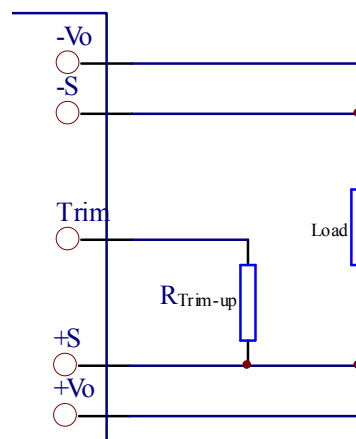

Connection of Trimming Up

Resistance for trimming up :

$$R_{Trim-up} = \left(\frac{5.11 \times Vo(100(\%) + \Delta(\%))}{1.225 \times \Delta(\%)} - \frac{5.11 \times 100(\%)}{\Delta(\%)} - 10.22 \right) (k\Omega)$$

$$R_{Trim-down} = \left(\frac{5.11 \times 100(\%)}{\Delta(\%)} - 10.22 \right) (k\Omega)$$

Resistance for trimming down:

Vo: rated output voltage, 5V;

R_{Trim-up}、R_{Trim-down}: Resistance for trimming up or down, kΩ;

Δ (%): Change rate, divide output voltage by rated output voltage.

For example, if the output voltage is 4.5V after adjusting 10% down, then Δ (%) = [(5-4.5)/5] × 100% = 10%,

R_{Trim-down} = 5.11 × 100% / 10% - 10.22 = 40.88 (kΩ), it can be taken as 35.7~36kΩ;

If the output voltage is 5.5V after adjusting 10% up, then Δ (%) = [(5.5-5) / 5] × 100% = 10%,

R_{Trim-up} = [(5.11 × 5 (100% + 10%)) / 1.225 × 10%] - [(5.11 × 100%) / 10%] - 10.22 = 168.1(kΩ), it can be taken as 150~160kΩ;

When testing the output overvoltage protection, use the R_{Trim-up} formula above to bring 50% into the formula to obtain 42.1(kΩ), it can be taken as 39~42kΩ.

External Capacitance

Unless special purpose (i.e. prolonging hold-up time, input impedance matching), the recommended input filter's capacitance ranges 68μF~220μF, which not only offers a stable system, and reduces the cost, but also lessens the inrush current when the power supplies, optimizes the power supply source, and improves system reliability.

When larger capacitance is required, a circuit of suppressing the inrush current is recommended when the regulator start-up and a discharge circuit is recommended when the output dropped, ensuring the reliability and safety of other equipments in the system.

The maximum capacitive load capacity of the power supply itself is 5000uF. To reduce output ripple or reduce the current impact on the power supply during load transients, the output filtering electrolytic capacitor can be appropriately increased. If there are no special requirements, it is recommended to connect a capacitance of

RAGS25-24A05 DC-DC Converters

Input 16V~40V, Output 5V/5A, One Sixteen Standard Brick

100~1000μF.

Due to the decrease in capacitance and increase in ESR value of electrolytic capacitors at low temperature, it is recommended to choose solid-state capacitors with better low-temperature characteristics if lower output ripple is required within the full operating temperature range (-40~85°C). At the same time, connect a differential mode inductance (0.22-0.33uH, ≥8A) before the output energy storage filtering electrolytic capacitor, This circuit facilitates lower output ripple requirements.

Remote Control

Remote control can be offered by setting right control voltage level (or floating、high resistance) to CNT pin. Positive logic remote control and negative logic remote control functions are optional, RAGS25-24A05 is provided with positive logic remote control. When the level is 3.5V~15V or be left floating, the converter will be turned on. When the level is 0V~0.5V, the converter will be off. When low level applied, the outflow current from the CNT pin is less than 2mA, and when high level (3.5~15V) applied, the inflow current from the CNT pin is less than 2mA.

Due to the internal logic comparator is a semiconductor integrated device, it has low endurance to surge. In practical applications, when introducing a voltage source that may cause surge voltage to the external signal, attention should be paid to the anti surge protection of the CNT, such as adding TVS tubes or bypass ceramic capacitors, to ensure that the CNT pins are not damaged by surge voltage. When the pin is floated, the voltage is approximately 1.25V-3.5V. The above diagram shows the recommended circuit for transistor control. If there is an isolation requirement for remote control in customer applications, the transistor can be replaced with an optocoupler to achieve isolation control.

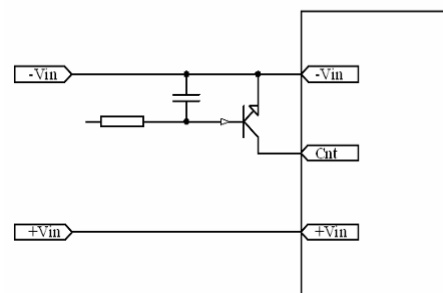

Internal Circuit Diagram For Logic Control

RAGS25-24A05P is provided with negative logic remote control. It has the same characteristic as RAGS25-24A05, except control logic. When the level is less than 0.5V, the converter will turn on. When the pin is left floating or the voltage of the pin is 3.5V~15V, the converter will turn off. As with positive logic products, attention should also be paid to the protection of CNT surge voltage. When the pin is floated, the voltage is approximately 2.5V~12.5V.

The use of remote control functions can provide users with convenience in control. For example, using remote control function to achieve remote control on/off function; When using in series parallel or when multiple devices are started simultaneously, the system can also use signals to synchronize the output voltage of the module.

This product is a positive logic control. When the signal provided by the application end system exceeds the range of 3.5V~15V, or when the system requires only a very narrow control signal level to play a control role, an auxiliary circuit needs to be added outside the module power supply. If you need a specific solution, please contact us.

Remote Sense

The remote sense can be used to compensate for the voltage drop between the output pins of the converter and the load input pins by +S、-S pins. The +S and -S pins should be connected to the input pins of the load respectively. The remote sense circuit will compensate for up to 10% voltage drop between the sense voltage and the voltage at the output pins, about 0.5V.

The anti-interference design should be considered when the +S、-S pins are connected to the pins to be compensated. The +S、-S traces should be located close to a ground trace or ground plane, and the area they surrounded should be minimized (just for electrical isolation); If cable connection presents, twisted pair wires should be used, EMI core are equipped with the twisted pair wires to reduce common mode noise when necessary, the sense leads should not be longer than 200mm, or the system characteristics may not be assured.

The sense leads only can carry very little current, and are not used for converter power output. Care should be taken in operation to avoid damaging the converter. To avoid damage caused by abnormal operations when not using the functions, it is recommended to use +S and +Vo, -S and -Vo short circuiting.

RAGS25-24A05 DC-DC Converters

Input 16V~40V, Output 5V/5A, One Sixteen Standard Brick

Over Temperature Protection(OTP)

The entire series of products are provided over temperature protection function, and the typical temperature protection point inside the module is 115°C. Due to the thermal resistance of the sealing adhesive, the typical temperature at the center of the heat dissipation plate is 105°C when heat is transmitted to the center position. The location of the test points is shown in the diagram below. (Under thermal balance, the temperature at any position of the product case is consistent.)

When using, please ensure that the test point position is less than 90°C and there is sufficient temperature derating left to prevent the power module from entering an over temperature protection state. When over temperature protection occurs, the module power supply will turn off. After the temperature drops by approx 10°C, the module power supply will restart. The duration of over temperature protection depends on the surrounding heat dissipation environment, and can range from seconds to minutes. If the high-temperature environment cannot be improved and the working status of the module remains unchanged, the restart process will continue.

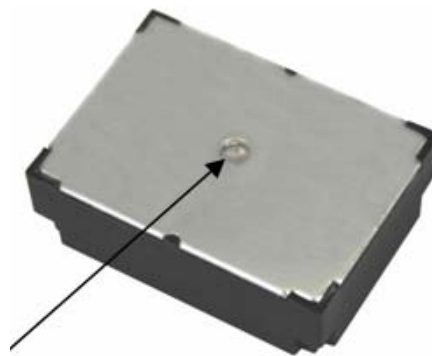
**Test point location****Output Over Voltage Protection(OVP)**

This product has an output over voltage protection function. When the output voltage exceeds 110%~150% of the rated voltage (the set point is between 110%~150%, there is the difference based on the specific parameters, but not beyond the range), the output voltage will be fluctuant when output is no-loaded. The clamping voltage fluctuates between 110% and 150% V_o , the output voltage is in an intermittent start state when the output is loaded. In the above two states, if the abnormal output overvoltage state disappears, the module can automatically enter the normal working state.

Series and Parallel Operation

The converters should not be paralleled directly to increase power, but they can be paralleled each other through o-ring switches or diodes. Make sure that every converter's maximum load current should not exceed the rated current at anytime if they are paralleled without using external current sharing circuits.

The converters can operate in series. To prevent against start-up failure due to start up time difference, SBD with low voltage difference can be paralleled at the output pins(SBD negative terminal connect to the positive pin of the output) for each converter.

Thermal Consideration

The converters can operate in a variety of thermal environments, however, sufficient cooling should be provided to improve its reliability and life. The heat generated by the power module loss can be released externally through radiation, convection, and conduction.

Example: how to select the minimum wind speed required (without additional heatsink). If the power module operates at an ambient temperature of 65°C, $V_{in}=24V$, and the output current is 5A, according to the derating curve 3 above, the minimum wind speed required is about 0.1m/s (natural wind).

The derating curve 3 in this instruction is simulated test data. The connection method during testing is similar to that obtained by inserting module pins into the test board. The actual use by the customer is welding to the motherboard, and the pin welding method can reduce thermal resistance. The thermal performance will be

RAGS25-24A05 DC-DC Converters

Input 16V~40V, Output 5V/5A, One Sixteen Standard Brick

significantly improved. The input and output currents in the power circuit are relatively high, and it is recommended that the current density of the cloth board be less than $6A/mm^2$. Therefore, the derating curve 3 is for reference only. The actual thermal resistance is related to heat conduction, convection, radiation, and the presence of nearby heat sources. Accurate evaluation is required based on the specific heat dissipation situation during actual use.

When adding air cooling, attention should be paid to the design of the air duct to avoid blocking the hot air or generating eddy currents, which may affect the heat dissipation effect; When adding a heat sink, the module heat dissipation substrate and heat sink should be tightly bonded. According to specific needs, thermal grease, thermal conduction double-sided adhesive or thermal silicone pad can be used to reduce the thermal resistance of heat dissipation.

Customers should optimize the heat dissipation design of the module as much as possible in practical applications, leaving sufficient design margin for the module case temperature or heat dissipation substrate temperature to avoid the module entering an over temperature protection state. Thus improving the reliability and service life of the power supply.

Safety Consideration

The converter, as a component for the end user, should be installed into the equipment, and all the safety considerations are achieved under certain condition. It is required to meet safety requirements in system design. The converter output is considered SELV, and the expected input is considered TNV2, the primary to secondary is basic insulation to EN60950. The maximum operating temperature for PCB is $170\text{ }^{\circ}\text{C}$.

To avoid fire and be protected when short circuit occurred, it is recommended that a fast blow fuse with rating 2.5 to 3 times of converter's continuous input peak current is used at the input terminal.

ESD Control

The converters are processed and manufactured in an ESD controlled environment and supplied in conductive packaging to prevent ESD damage from occurring before or during shipping. It is essential that they are unpacked and handled using an ESD control procedures. Failure to do so affects the lifetime of the converter.

Cleaning Notice

The converter is suitable for water washing, because it does not have any pockets where water could be trapped long-term. Users should ensure that the drying process is adequate and of sufficient duration to remove all water from the converter after washing, do not power up the unit until it is completely dry.

Delivery Package Information

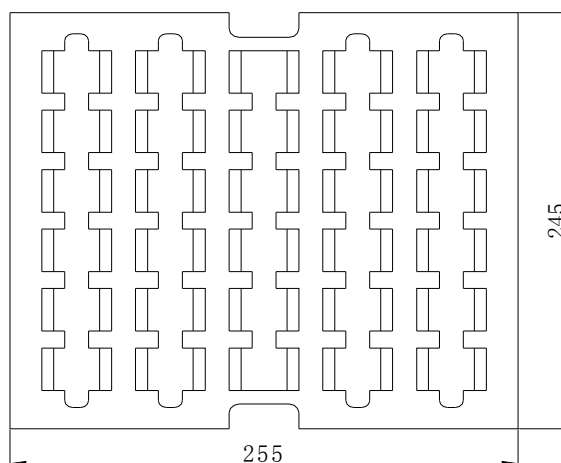

RAGS25-24A05 DC-DC ConvertersInput 16V~40V, Output 5V/5A, One Sixteen Standard Brick

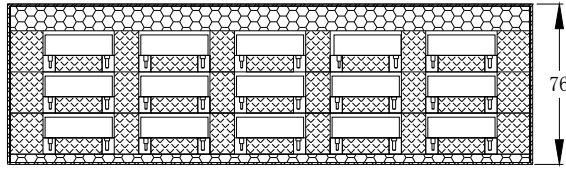

Package material is multiple wall corrugated, internal material is anti-static foam, it's surface resistance is from $10^5 \Omega$ to $10^{12} \Omega$. Tray capacity: $3 \times 30 = 90$ PCS/box, Tray weight: 3.3kg; Carton capacity: $4 \times 90 = 360$ PCS, Carton weight: 14.5kg.

Quality Statement

The converters are manufactured in accordance with ISO 9001 system requirements and are monitored 100% by auto-testing system, 100% burn in.

The warranty for the converters is 5-year.