

ZDR20-48BS3V3ST DC-DC Converters

Input 18V-75V, Output 3.3V/6A, 1in.×1in. Standard Size

Contents

Contents..... 1

Ordering Information..... 1

Outline Diagram 2

Specification 2

Characteristic Curves..... 4

Design Considerations..... 5

 Basic Connection..... 5

 Recommended Layout 6

 Input Voltage Range..... 6

 Remote Control..... 6

 External Capacitance 7

 Thermal Consideration 7

 Safety Consideration..... 7

 Series and Parallel Operation..... 7

 ESD Control 7

Quality Statement 7

Contact Information..... 8



Features

- ◆ 1in.×1in. Compact Size (25.4 mm×25.4 mm ×10.5mm)
- ◆ 18 to 75Vdc Wide Input Voltage Range
- ◆ Positive Logic Control (3.5V to 15V or floating Turn on)
- ◆ Output Short-circuit Protection, automatic recovery
- ◆ High Efficiency up to 89% (48V, full load)
- ◆ 2250Vdc Isolation Voltage
- ◆ Operation Case Temperature -40°C to +105°C
- ◆ Surface mount (SMT) or Through hole (TH)
- ◆ Applications: Instruments, vehicle-mounted equipment and other high-reliability fields, distributed power architecture, etc.

Ordering Information

See Contents for individual product ordering numbers.

Suffix	Description	Ordering No.
--	Positive Logic Control	ZDR20-48S3V3T
N	Negative Logic Control	ZD20-48S3V3NT
S	Surface mount (SMT)	ZDR20-48S3V3ST
NS	Negative Logic Control, Surface mount (SMT)	ZDR20-48S3V3NST

ZDR20-48BS3V3ST DC-DC Converters

Input 18V-75V, Output 3.3V/6A, 1in.×1in. Standard Size

Outline Diagram

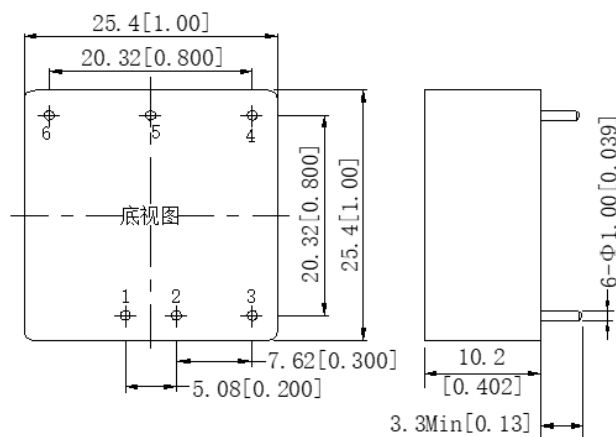

(TH package)

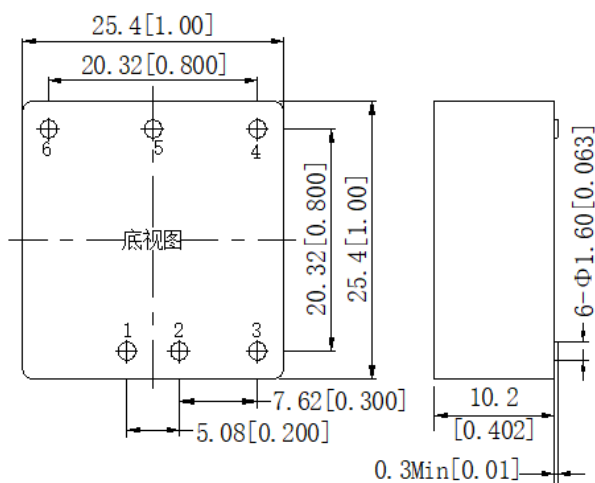

(SMT package)

Pin	Symbol	Function
1	+Vin	Positive Input
2	-Vin	Negative Input
3	CNT	Remote Control Pin
4	-Vo	Negative Output
5	COM	Common ground
6	+Vo	Positive Output

Case material:

Aluminum, black; Pin: copper with tin-cerium plating

Notes: all dimensions in mm(inches)

Tolerances: X.X ±0.5mm(X.XX ±0.02)

X.XX ±0.25mm(X.XXX ±0.010)

Specification

Unless otherwise specified, all values are given at: 25°C, one standard atmosphere pressure, pure resistive load and basic connection.

Input		Symbol	Min	Typ	Max	Unit	Conditions
Input Voltage		V _{in}	18	24/48	75	Vdc	—
Input Voltage max.		V _{in max}	—	—	100	Vdc	100ms
Input Current		I _{in}	—	—	1.3	A	V _{in} =18Vdc, I _O =±1.5A
No-load input current		I _{in nl}	—	—	40	mA	V _{in} =9Vdc, I _O =0A
Positive Logic Remote Control	ON	—	3.5	—	15	V	Refer to -V _{in} Also turn on when REM floating.
	Input current	—	—	—	0.5	mA	The input current of the REM
	OFF	—	0	—	1.5	V	Refer to -V _{in}
	Output current	—	—	—	1.0	mA	The output current of the REM

ZDR20-48BS3V3ST DC-DC Converters

Input 18V-75V, Output 3.3V/6A, 1in.×1in. Standard Size

Output	Symbol	Min	Typ	Max	Unit	Conditions
Output Voltage	V_{O1}	3.25	3.30	3.35	Vdc	—
Output Current	$I_{O1,nom}$	0	—	6	A	—
Line Regulation	S_V	—	—	±0.2	% V_O	V_{in} : 18~75Vdc, $I_O=6A$
Load Regulation	S_I	—	—	±0.5	% V_O	$V_{in}=48V$, $I_O: 0A\sim 6A$
Output Over Current Protection Range	$I_{O,lim}$	110	-	170	% I_O	$V_{in}=48V$
Output Overshoot	V_{TO}	—	—	10	% V_O	$V_{in}=48V$, pure resistive load
Output Short-circuit Protection	automatic recovery					—

Continue

Output	Symbol	Min	Typ	Max	Unit	Conditions
Peak to Peak Ripple and Noise	ΔV_{pp}	—	—	75	mV	20MHz bandwidth
Rise Time	T_{rise}	—	5	—	ms	$V_{in}=24V$, pure resistive load
Capacitive Load	C_O	0	—	1000	μF	pure resistive load
Load Transient	Recovery Time	t_{tr}	—	200	—	25%~50%~25% $I_{O,nom}$ or 50%~75%~50% $I_{O,nom}$; 0.1A/μs
	Voltage Deviation	ΔV_{tr}	—	±165	—	

General	Symbol	Min	Typ	Max	Unit	Conditions
Efficiency	η	86.5	88	—	%	$V_{in}=48V$, $I_{O,nom}$
Switching Frequency	f_s	—	300	—	kHz	—
Isolation Resistance	R_{iso}	50	—	—	MΩ	—
Relative Humidity	—	—	—	90%	RH%	Frost free
MTBF	—	—	2×10^6	—	h	BELLCORE TR-332,
Isolation Voltage	V_{iso}	2250	—	—	Vdc	Input to output
Operating case Temperature	—	-40	—	+105	°C	—
Storage Temperature	—	-55	—	+125	°C	—
Temperature Coefficient	S_T	—	—	±0.02	%/°C	—
Hand Soldering	Maximum soldering Temperature < 425°C, and duration < 5s					
Wave Soldering	Maximum soldering Temperature < 255°C, and duration < 10s					

ZDR20-48BS3V3ST DC-DC Converters

Input 18V-75V, Output 3.3V/6A, 1in.×1in. Standard Size

Characteristic Curves

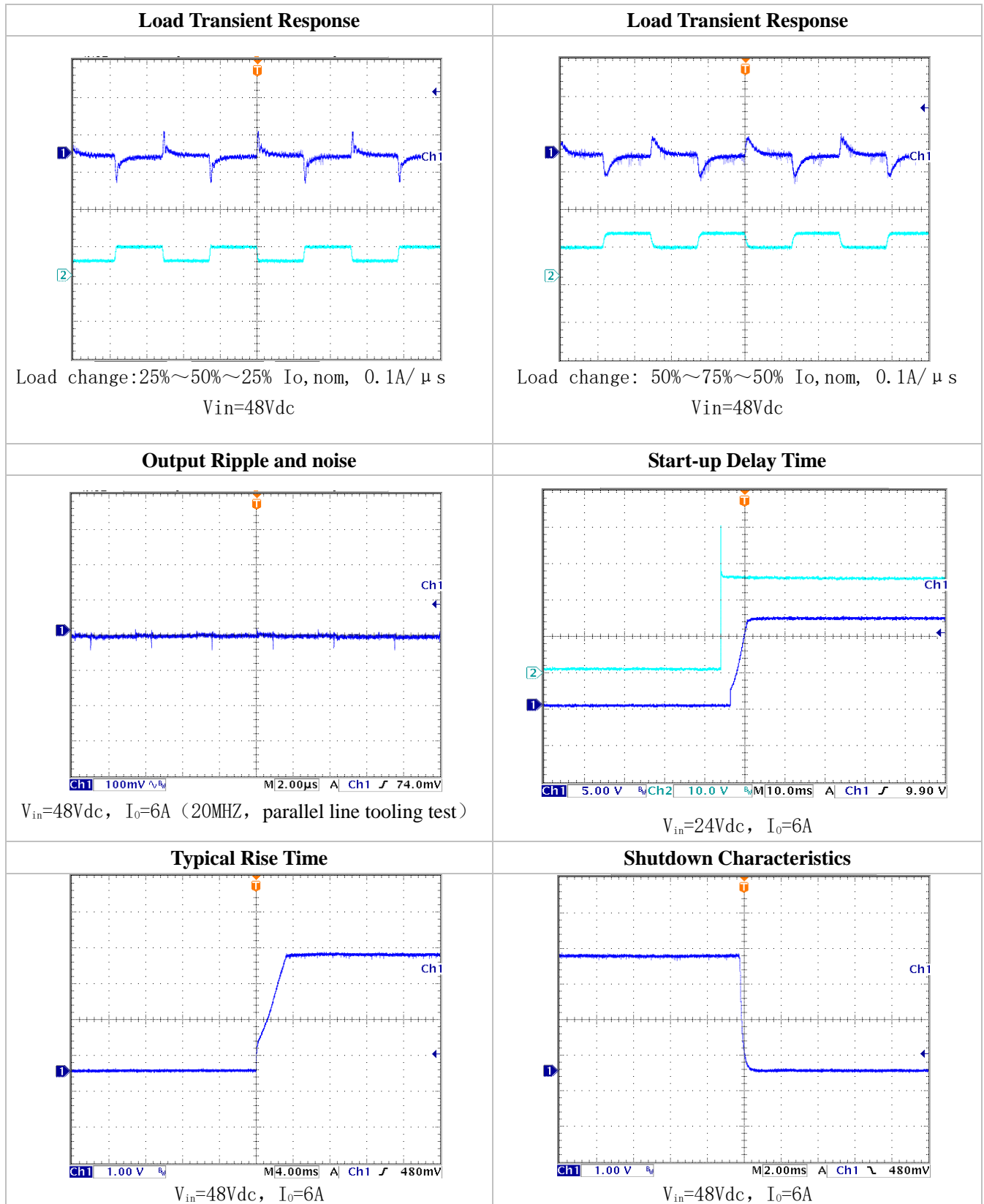

ZDR20-48BS3V3ST DC-DC Converters

Input 18V-75V, Output 3.3V/6A, 1in.×1in. Standard Size

Efficiency vs Io & Vin

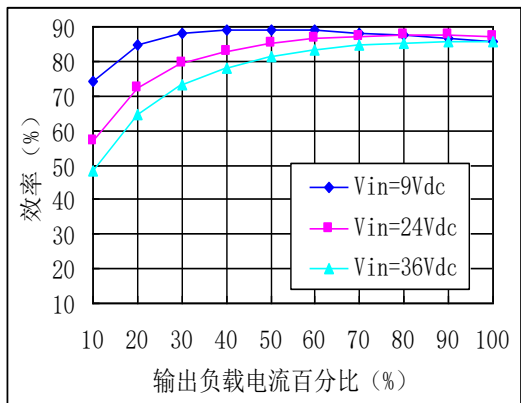

Design Considerations

Basic Connection

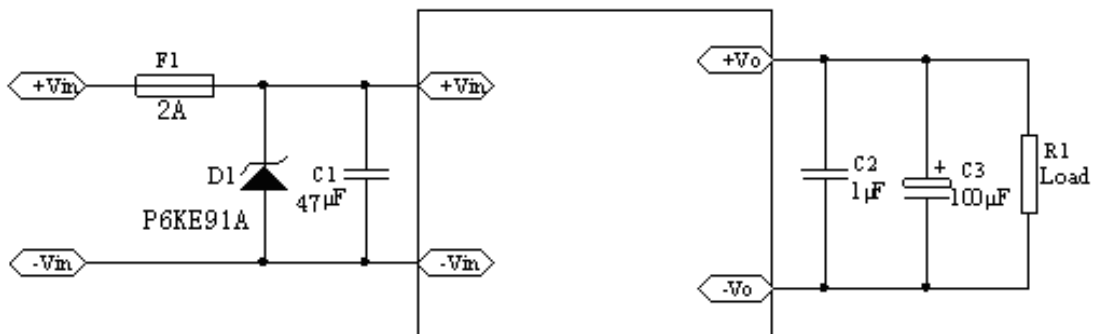

Notes: The basic connection indicates the basic requirements that the power module can provide rated output voltage and rated power only. Please refer the instruction followed for further information.

ZDR20-48BS3V3ST DC-DC Converters

Input 18V-75V, Output 3.3V/6A, 1in.×1in. Standard Size

Recommended Layout

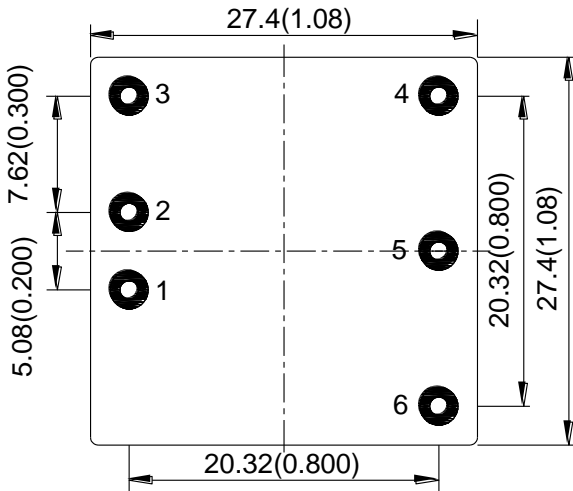

NO.	Recommendation & Notes
Pad Design	TH package: Pad holes: 1.3mm, pad diameter including hole:3.5mm; SMT package: Pad ϕ 2.0mm
Installation direction	The metal heat sink faces upward to make the hot air flow.
Safety	Isolated Converters, care to the spacing between input and output.
Electrical	The Vin (-) and Vo (-) planes should be placed under of the converter separately. Avoid routing sensitive signal or high disturbance AC signal under the converter.

Input Voltage Range

The input voltage range of the DC/DC converter is 18V to 75V。 The input impedance of the converter looks like a negative resistor, which can interact with the reactance of the power bus (including any filter elements that have been added to the input of the converter), causes an unstable condition. Depending on the internal transformer’s impedance, the external impedance usually should not exceed the 10% of the internal. So, the source impedance of the Power bus should be kept as low as possible.

The method to determine whether the impedance of the power bus too high or not is to decrease the converter’s input voltage from higher to lower gradually, if the output voltage decreases (unstable sometime) with the lower input voltage, it will be considered the impedance too large. For further confirmation, one electrolytic capacitor can be paralleled to the converter pins after the converter shuts down (one 1 μ F ceramic capacitor may be required to be paralleled with the electrolytic capacitor), if the output getting better, it will be sure that the impedance is too large.

Remote Control

Remote control can be offered by setting right control voltage level (or floating) to CNT pin. ZDR20-48S3V3T is provided with positive logic remote control. When the level is between 3.5V and 15V or be left floating, the converter will be turned on. When the level is less than 1.5V, the converter will be turned off. When low voltage level is applied, the output current of the REM is less than 1.0mA. When high voltage level (3.5V~15V) is applied, the input current of the REM is less than 0.5mA.

Due to the logic comparator is semiconductor integrated chip, they have low endurance to surge. Care should be taken to prevent REM from surge, A TVS should be used in some cases. When the pin is left floating, 2.0V-6.0V voltage appears on the pin.

In some applications, extra controls will be designed for the converter in user’s PCB, such as output short circuit protection, over voltage protection, under voltage protection, and so on, remote control will give you help. The controls can be achieved by external circuit applied to the CNT pin.

ZDR20-48BS3V3ST DC-DC ConvertersInput 18V-75V, Output 3.3V/6A, 1in.×1in. Standard Size

In some applications it is necessary to have a precise turn on and turn off level, or the level which can be received has a very narrow range, the aux. circuit will be required. Please contact us for more information.

External Capacitance

Unless special purpose (i.e. prolonging hold-up time, input impedance matching), the recommended input filter's capacitance ranges 47 μ F-100 μ F, which not only offers a stable system, and reduces the cost, but also lessens the inrush current when the power supplies.

When larger capacitance is required, a circuit of suppressing the inrush current is recommended when the regulator start-up and a discharge circuit is recommended when the output dropped, ensuring the reliability and safety of other equipment in the system.

Thermal Consideration

The converters operate in a variety of thermal environments; however, sufficient cooling should be provided to ensure reliable operation of the unit. Heat is removed by conduction, convection and radiation to the surrounding environment. For the specified ambient temperature, user can increase airflow and change the size of heatsink to improve the heat dissipating for the module with baseplate; user can only increase airflow to improve the heat dissipating for the models without heat sink. Note that the natural convection condition means that airflow is 0.1m/s.

Safety Consideration

The converter, as a component for the end user, should be installed into the equipment, and all the safety considerations are achieved under certain condition. It is required to meet safety requirements in system design. The converter output is considered SELV, and the expected input is considered TNV2, the primary to secondary is basic insulation to EN60950. The maximum operating temperature for PCB is 150 °C.

To avoid fire and be protected when short circuit occurred, it is recommended that a fast blow fuse with rating 2.5 to 3 times of converter's continuous input peak current is used at the input terminal.

Series and Parallel Operation

The converters should not be paralleled directly to increase power, but they can be paralleled each other through o-ring switches or diodes. Make sure that every converter's maximum load current should not exceed the rated current at anytime if they are paralleled without using external current sharing circuits. For the case that there is no external current sharing circuit, but power needs to be increased, please use Trim pin to adjust each converter's output voltage, to load the current as equal as possible in operating (When the load changes in a wide range, the method will not work).

The converters can operate in series. To prevent against start-up failure due to start up time difference, SBD with low voltage difference can be paralleled at the output pins. (SBD negative terminal connect to the positive pin of the output) for each converter.

ESD Control

The converters are processed and manufactured in an ESD controlled environment and supplied in conductive packaging to prevent ESD damage from occurring before or during shipping. It is essential that they are unpacked and handled using an ESD control procedures. Failure to do so affects the lifetime of the converter.

Quality Statement

The converters are manufactured in accordance with ISO 9001 system requirements, and are monitored 100% by

ZDR20-48BS3V3ST DC-DC ConvertersInput 18V-75V, Output 3.3V/6A, 1in.×1in. Standard Size

auto-testing system, 100% burn in. The warranty for the converters is 5-year.

Contact Information

*Anhui Hesion Trading Co.,Ltd.
& Beijing Zhengxinyuan Technology Co.Ltd.*

TEL:+86-551-65369069,65369067

Email: alecz@ahhesion.com

Backup:alecz@126.com

www.ahhesionpower.com