

Features

- ◆ Size :50.8mm×40.6mm×12.7mm
- ◆ Input voltage range: 0- 50 Vdc,
16.5-50Vdc work
- ◆ Transient protection MIL-STD-1275
A/B/D (Positive impact protection)
- ◆ Surge suppression
- ◆ EMI filtering
- ◆ 1500Vdc Input / Output to Base / FG
- ◆ Case temperature : -40°C to +100°C



TSL50S10

Outline

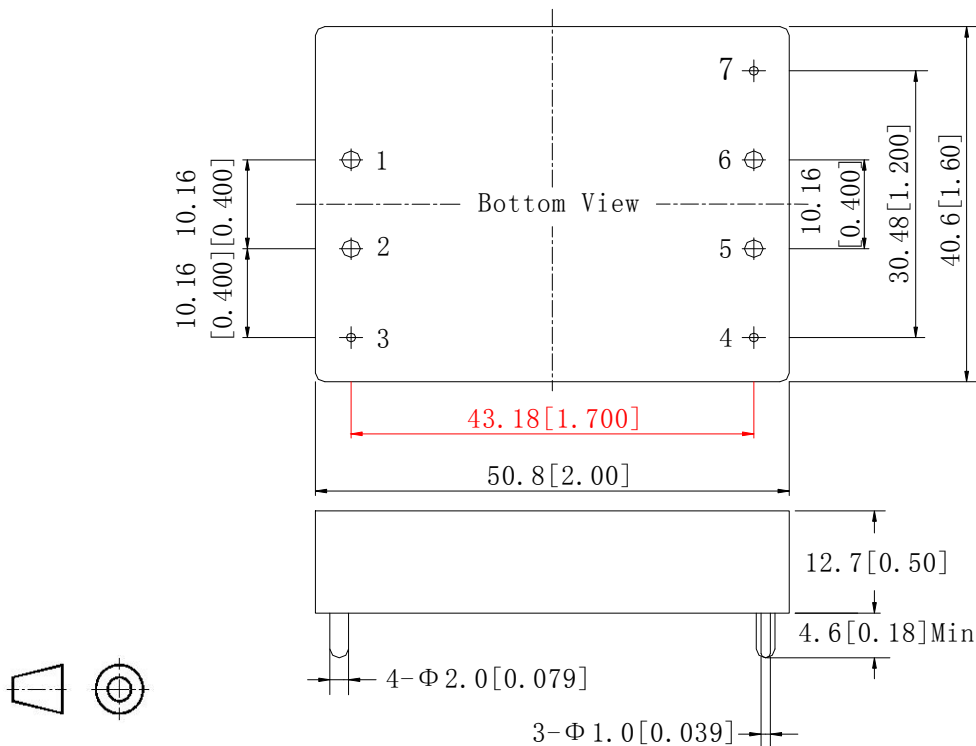

Pin	Symbol	Function	Pin	Symbol	Function	Notes
1	+Vin	Input voltage positive	5	-Vo	Output voltage negative	Case material: Aluminium alloy; Pins material: Copper, tin-cerium plating; Units: mm(inches) ; Tolerance: X.X±0.5,(X.XX±0.02) X.XX±0.25(X.XXX±0.010)
2	-Vin	Input voltage negative	6	+Vo	Output voltage positive	
3	FG	EMI GND	7	NC	No connect	
4	Cnt	Control pin				

Specifications

Unless otherwise specified, all values are given at: 25°C, one standard atmosphere pressure, basic connection.

Input Specifications		Min	Typ	Max	Unit	Notes
Recommend input voltage range		18	24	36	V	Continuous
Input Working voltage range		16.5	24	50	V	Continuous
Absolute input voltage range		-0.7	—	250	V	<u>With 125W max. limit:</u> 250V:70 μs 100V:50ms 80V:100ms 70V:120ms 50V: Continuous <u>No load:</u> 250V:70 μs 100V: Continuous
External input capacitance		10	100	—	μF	FIG1 Cin
Negative logic	on	-0.7	0	0.3	V	Cnt refer to -Vo
	off	—	—	15	V	Cnt refer to -Vo; Cnt left: module off

Output Specifications		Min	Typ	Max	Unit	Notes
Output voltage range		16	24	49.5	V	
Internal voltage drop		—	—	1	V	
Output current		0	—	10	A	125W max. limit 8A: Continuous 10A:100ms after startup
External output capacitance		470	1000	—	μF	FIG1 Cout

General Specifications		Min	Typ	Max	Unit	Notes
Efficiency		—	98	—	%	Full load
Dielectric withstand		1500	—	—	Vdc	Input / Output to Base /FG, 1minute, 5mA
EMI		Common mode: 26dB Differential mode: 35dB				
Case Temperature		-40	—	100	°C	
Storage Temperature		-55	—	125	°C	
Relative Humidity		10	—	90	%RH	
Manual Soldering		—	—	425	°C	5s max
Wave Soldering		—	—	260	°C	10s max
Weight		—	43	—	g	

Characteristic Curves

Start-up

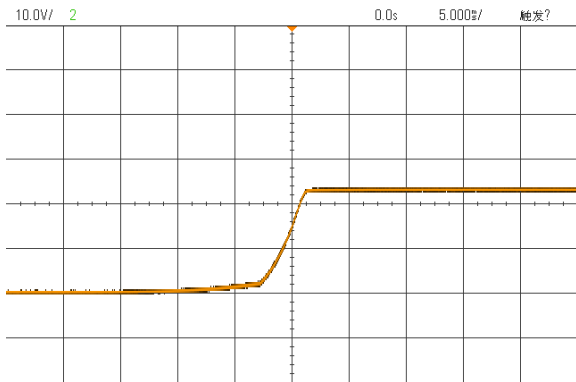

24V in, 8A output with 10 μ F input capacitance and 1000 μ F output capacitance

Start-up

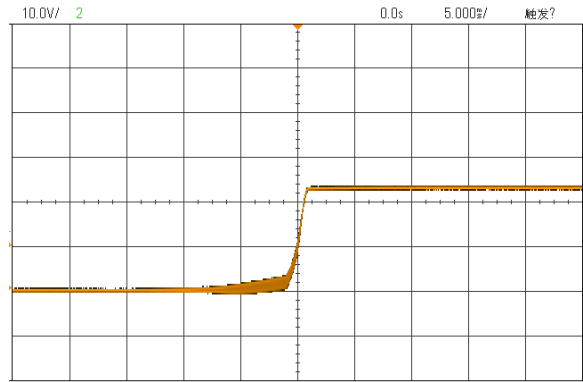

24V in, 8A output with 10 μ F input capacitance and 0 μ F output capacitance

Turn-off

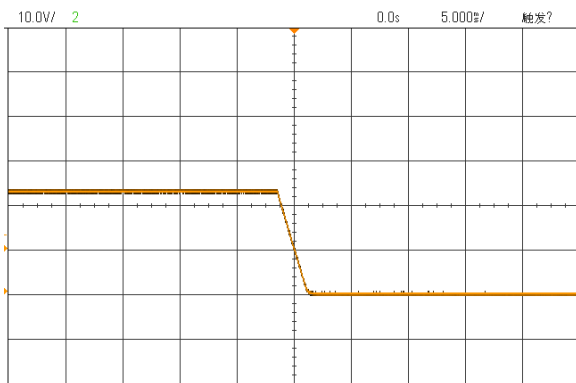

24V in, 8A output with 10 μ F input capacitance and 1000 μ F output capacitance

Turn-off

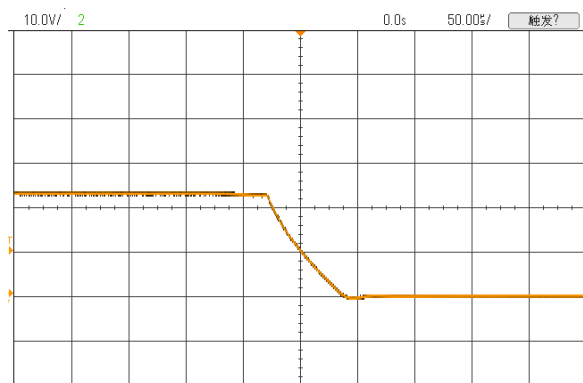

24V in, 8A output with 10 μ F input capacitance and 0 μ F output capacitance

Load Transient Response

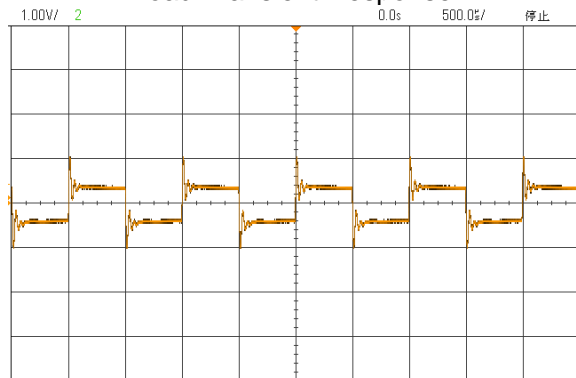

24V in, Load change 0A-5A-0A, 1A/ μ s

Load Transient Response

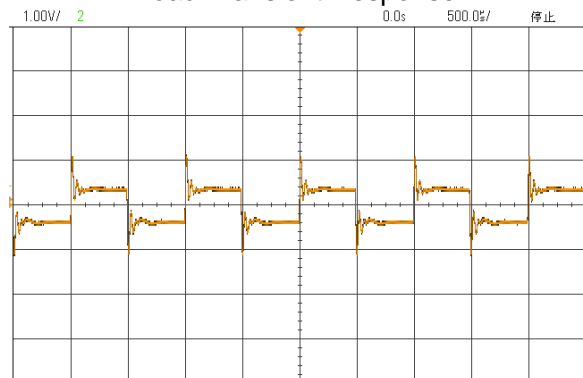

24V in, Load change 5A-10A-5A, 1A/ μ s

Transient protect

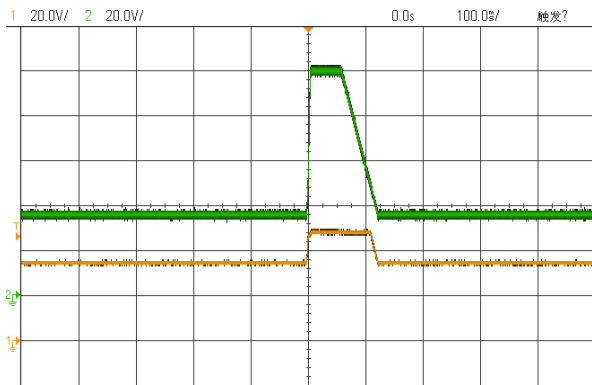

36V in, 100V pulse(60ms continuous, 60ms down to 36V) , with 10 μ F input capacitance and 1000 μ F output capacitance

Transient protect

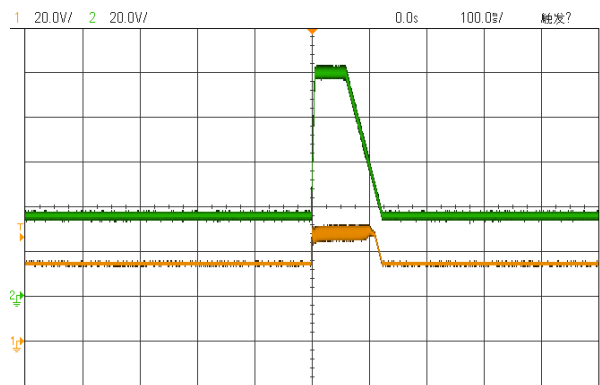

36V in, 100V pulse(60ms continuous, 60ms down to 36V) , with 10 μ F input capacitance and 0 μ F output capacitance

Efficiency Curve

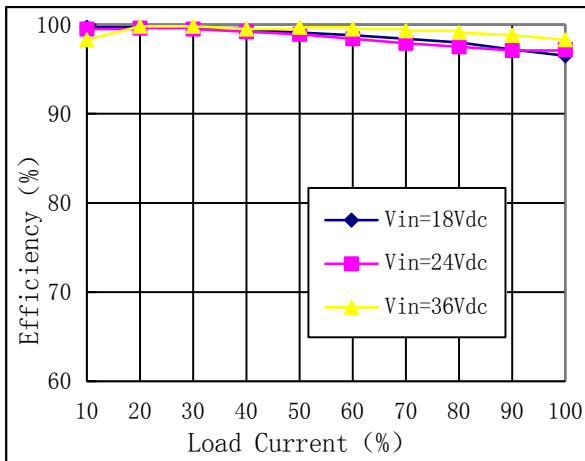

Derating

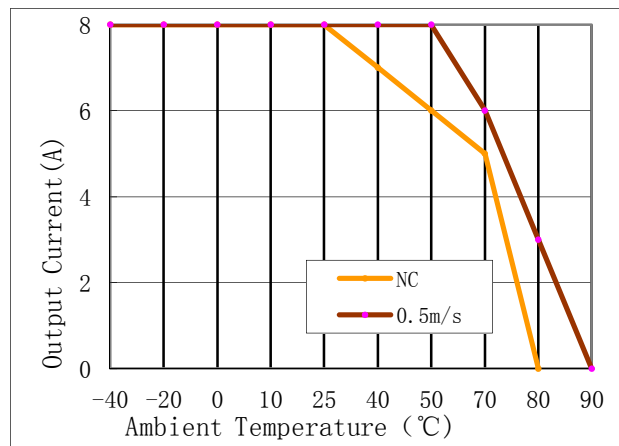

Connection

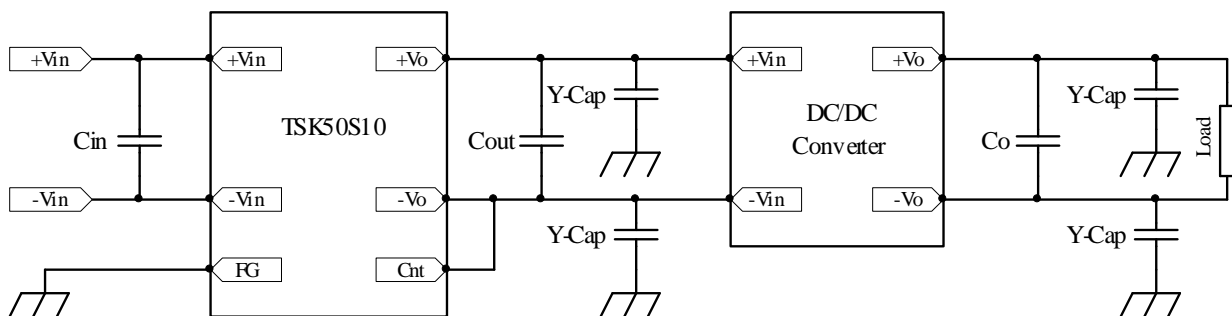

FIG1 Basic connection of TSK50S10

Notes:

1. The basic connection indicates the basic requirements that the module can provide rated output voltage and rated power only. Please refer the instruction followed for further information.

2. There are two capacitors connected from FG to +Vin and –Vin in the TSK50S10.
3. Y-Cap will be selected by the EMI requirement.
4. Pin FG can be float according to de EMI requirement.

Cleaning Notice

The module case is not a hermetically-sealed construction, a sufficient drying process is required after the converter cleaning, make sure the liquid congregated is removed, or it will damage the converter or degradation of performance.

After surface treatment, the appearance of the converter may be affected by the organic solvent, protection measures should be taken before cleaning when appearance is concerned.

Contact Information

*Anhui Hesion Trading Co.,Ltd.
& Beijing WiEN Electronic Technology Co.,Ltd.*

*TEL:+86-551-65369069,65369067
Email: alecz@ahhesion.com
Backup:alecz@126.com*

www.ahhesionpower.com